



**REXNORD® EXTREME
PERFORMANCE ROLLER
CHAIN CATALOG**
METRIC



Rexnord® Extreme Performance Roller Chain for the Most Demanding Applications





Introduction to the Regal Rexnord™ Extreme Performance Portfolio

Increasing market demands for extreme performance chain has driven Regal Rexnord to develop a product portfolio* suitable for heavy loading capacities and high fatigue resistance:

- Rexnord® RexAthletic® Roller Chain page 4
- Rexnord RexHiPro® Roller Chain page 10
- Rexnord RexHiProAthletic® Roller Chain page 14
- Rexnord ReXtreme® Roller Chain page 18
- Rexnord RexCarbon® Roller Chain page 22
- Rexnord RexProX® Roller Chain page 26
- Rexnord RexPlus® Roller Chain page 29
- Rexnord RexPlusCarbon® Roller Chain page 34

* All the chains are also available with attachments and extended pins. For prices, leadtimes and minimum order quantities please consult our current price book or contact Regal Rexnord.

Rexnord Extreme Performance Chain will deliver:

- Improved wear resistance
- Improved dynamic and static safety
- Increased chain joint loading capability
- Improved hygiene
- Increased corrosion protection

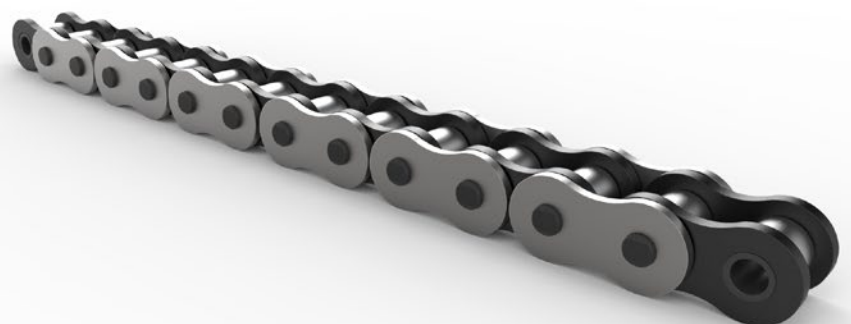



Rexnord® RexAthletic® Roller Chain

Extreme Performance

Rexnord RexAthletic **low-maintenance** Roller Chain contains low-friction chain joints and provides long relubrication intervals. This chain features high dynamic loading capabilities, long wear life and high wear resistance.

Low maintenance

Due to the high performance long-term lubrication the friction and the need for maintenance is reduced and the lubrication intervals are significantly longer. This is ideal in case the maintenance and lubrication possibilities are limited. The special coating of the pins and bushes offers a very good sliding characteristic.

High dynamic loading capability

The Rexnord RexAthletic Roller Chain is ideal for heavy loading applications in difficult conditions and in closed systems. It's also suitable for situations where high fatigue resistance is required.

Features

- Outstanding tribological characteristics
- Excellent sliding properties
- High fatigue strength and chain traction comparable with Rexnord High Performance Chains
- Improved protection against chain joint stiffness
- NSF H2 certification for the food industry
- Chain sizes with pitch from 12.7 millimeter (mm) to 50.8 mm available (special sizes on request)
- Dimensions in accordance with DIN, ANSI and ISO standards

Long wear life

Even with minimum lubrication and under heavy loads the Rexnord RexAthletic Roller Chain has a high wear resistance and a long wear life. The wear life is much longer compared to standard chains. The chain contains improved protection against stiff joints and links.

Advantages

- Reduced maintenance and longer lubrication intervals
- High wear resistance even with inadequate lubrication
- Extended wear life under tough loading conditions
- Cost-effective

Lubrication

- High quality long-term lubricant
- No dripping of lubricant
- Water-resistant
- Temperature range from 0 degrees Celsius (°C) to +120°C
- Temperature range extension from - 40°C to + 250°C possible with high- or low-temperature lubricants

Industries Served:

- Material Handling
- Automotive
- Food & Beverage
- Agriculture
- Energy
- General Mechanical Engineering

Rexnord® RexAthletic® Roller Chain

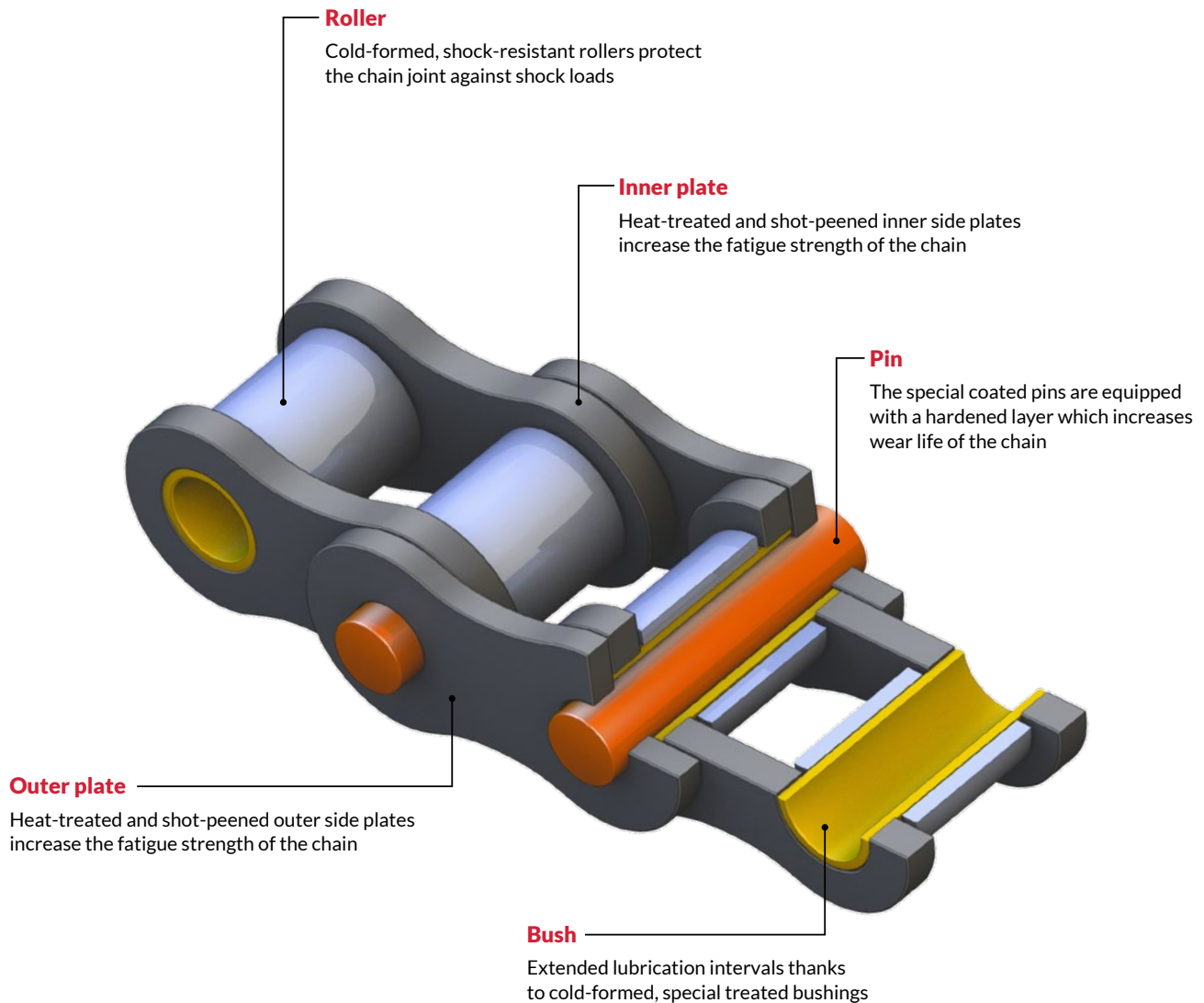

Loading capacity

- High loading capacity



Wear resistance

- Ideal where maintenance and lubrication possibilities are restricted
- Longer maintenance and lubrication intervals
- Long service life



Eco-friendly

- Less relubrication necessary
- Free of chromium VI
- NSF H2 certification



This product meets the requirements of Machine Directive 2006/42/EC

Chain No.	Pitch		Width between inner plates		Roller diameter	Pin diameter	Width over inner link	Plate depth	Transverse pitch	Pin length	Connecting pin length	Bearing area	Required minimum tensile strength DIN / ISO	Average tensile strength	Weight	Possible with straight sided plates	Loose parts				
	p	b ₁ min.	d ₁ max.	d ₂ max.	b ₂ max.	g	e	a ₁ max.	a ₃ max.	A	F _U	F _B	q	A	B		E*	L	S*		
	Inch	mm	mm	mm	mm	mm	mm	mm	mm	mm	mm	mm	mm	mm	mm		mm	mm	mm	mm	
08 B - 1 AT	0.50	12.7	7.75	8.51	4.45	11.30	11.6	-	17.0	20.9	0.50	17 800	21 000	0.7	x	x	x	x	x		
10 B - 1 AT	0.625	15.875	9.65	10.16	5.08	13.28	14.6	-	19.6	23.7	0.67	22 200	25 000	0.9	x	x	x	x	x		
12 B - 1 AT	0.75	19.05	11.68	12.07	5.72	15.62	15.9	-	22.7	27.3	0.89	28 900	32 000	1.2	x	x	x	x	x		
16 B - 1 AT	1.00	25.4	17.02	15.88	8.28	25.40	20.5	-	36.1	41.5	2.10	60 000	80 000	2.7	x	x	x	x	x		
20 B - 1 AT	1.25	31.75	19.56	19.05	10.19	29.00	25.7	-	40.4	47.6	2.96	95 000	120 000	3.8	x	x	x	x	x		
24 B - 1 AT	1.50	38.1	25.40	25.40	14.63	37.90	33.0	-	53.8	60.6	5.54	160 000	211 000	7.0	x	x	x	x	x		
28 B - 1 AT	1.75	44.45	30.99	27.97	15.90	46.50	37.0	-	63.3	72.8	7.35	200 000	240 000	8.9	x	x	x	x	x		
32 B - 1 AT	2.00	50.8	30.99	29.21	17.81	45.50	41.2	-	65.1	73.6	8.10	250 000	315 000	9.9	x	x	x	x	x		

* Loose parts are produced in Rexnord RexHiProAthletic version

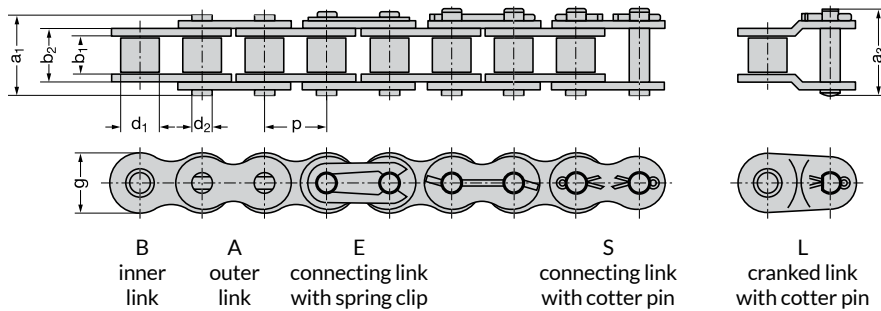

Chain No.	Pitch		Width between inner plates		Roller diameter	Pin diameter	Width over inner link	Plate depth	Transverse pitch	Pin length	Connecting pin length	Bearing area	Required minimum tensile strength DIN / ISO	Average tensile strength	Weight	Possible with straight sided plates	Loose parts				
	p	b ₁ min.	d ₁ max.	d ₂ max.	b ₂ max.	g	e	a ₁ max.	a ₃ max.	A	F _U	F _B	q	A	B		E*	L	S*		
	Inch	mm	mm	mm	mm	mm	mm	mm	mm	mm	mm	mm	mm	mm	mm		mm	mm	mm	mm	
08 B - 2 AT	0.50	12.7	7.75	8.51	4.45	11.30	11.6	13.92	30.6	34.9	1.01	31 100	43 000	1.4	x	x	x	x	x		
10 B - 2 AT	0.625	15.875	9.65	10.16	5.08	13.28	14.6	16.59	35.5	40.3	1.35	44 500	50 000	1.8	x	x	x	x	x		
12 B - 2 AT	0.75	19.05	11.68	12.07	5.72	15.62	15.9	19.46	41.7	46.8	1.79	57 800	64 000	2.3	x	x	x	x	x		
16 B - 2 AT	1.00	25.4	17.02	15.88	8.28	25.40	20.5	31.88	67.4	73.4	4.21	106 000	140 000	5.3	x	x	x	x	x		
20 B - 2 AT	1.25	31.75	19.56	19.05	10.19	29.00	25.7	36.45	76.9	83.6	5.91	170 000	230 000	7.5	x	x	x	x	x		
24 B - 2 AT	1.50	38.1	25.40	25.40	14.63	37.90	33.0	48.36	102.2	122.7	11.09	280 000	370 000	13.7	x	x	x	x	x		
28 B - 2 AT	1.75	44.45	30.99	27.97	15.90	46.50	37.0	59.56	122.8	132.7	14.69	360 000	480 000	17.8	x	x	x	x	x		
32 B - 2 AT	2.00	50.8	30.99	29.21	17.81	45.50	41.2	58.55	123.6	132.4	16.21	450 000	530 000	19.6	x	x	x	x	x		

* Loose parts are produced in Rexnord RexHiProAthletic version

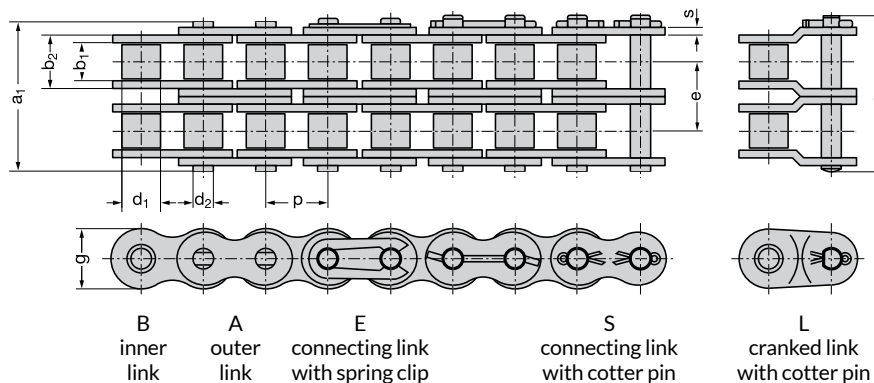

Chain No.	Pitch		Width between inner plates	Roller diameter	Pin diameter	Width over inner link	Plate depth	Transverse pitch	Pin length	Connecting pin length	Bearing area	Required minimum tensile strength DIN / ISO	Average tensile strength	Weight	Possible with straight sided plates	Loose parts				
	p		b_1 min.	d_1 max.	d_2 max.	b_2 max.	g	e	a_1 max.	a_3 max.	A	F_U	F_B	q		A	B	F*	L	S*
	Inch	mm	mm	mm	mm	mm	mm	mm	mm	mm	cm ²	N	N	kg/m						
08 B - 3AT	0.50	12.7	7.75	8.51	4.45	11.30	11.6	13.92	44.6	48.8	1.51	44 500	64 000	2.1	x	x	x	x		
10 B - 3AT	0.625	15.875	9.65	10.16	5.08	13.28	14.6	16.59	52.2	56.9	2.02	66 700	75 000	2.7	x	x	x	x		
12 B - 3AT	0.75	19.05	11.68	12.07	5.72	15.62	15.9	19.46	61.3	66.3	2.68	86 700	96 000	3.7	x	x	x	x		
16 B - 3AT	1.00	25.4	17.02	15.88	8.28	25.40	20.5	31.88	99.3	105.3	6.31	160 000	210 000	7.9	x	x	x	x		
20 B - 3AT	1.25	31.75	19.56	19.05	10.19	29.00	25.7	36.45	113.4	121.2	8.87	250 000	340 000	11.2	x	x	x		x	
24 B - 3AT	1.50	38.1	25.40	25.40	14.63	37.90	33.0	48.36	150.5	160.4	16.63	425 000	560 000	20.4	x	x	x		x	
28 B - 3AT	1.75	44.45	30.99	27.97	15.90	46.50	37.0	59.56	182.3	192.2	22.04	530 000	720 000	26.7		x	x		x	
32 B - 3AT	2.00	50.8	30.99	29.21	17.81	45.50	41.2	58.55	182.2	191.0	24.31	670 000	795 000	29.3	x	x	x		x	

* Loose parts are produced in Rexnord RexHiProAthletic® version

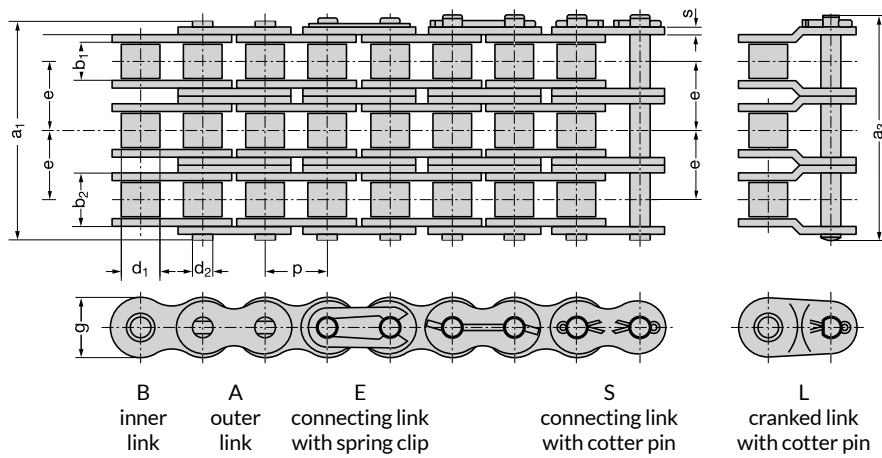

Chain No.	Pitch		Width between inner plates		Roller diameter	Pin diameter	Width over inner link	Plate depth	Transverse pitch	Pin length	Connecting pin length	Bearing area	Required minimum tensile strength DIN/ISO	Average tensile strength	Weight	Possible with straight sided plates	Loose parts				
	p		b ₁ min.	d ₁ max.	d ₂ max.	b ₂ max.	g	e	a ₁ max.	a ₃ max.	A	F _U	F _B	q	A		B	E*	L**	S*	
	Inch	mm	mm	mm	mm	mm	mm	mm	mm	mm	mm	cm ²	N	N	kg/m						
60-1 AT	0.75	19.05	12.57	11.91	5.94	17.70	17.8	-	25.7	28.6	1.05	31 300	40 000	1.5	x	x	x	x	x		
80-1 AT	1.00	25.4	15.75	15.88	7.92	22.50	23.6	-	33.0	38.0	1.78	55 600	65 000	2.6	x	x	x	x	x		
100-1 AT	1.25	31.75	18.90	19.05	9.53	27.40	29.2	-	39.4	44.9	2.61	87 000	105 000	4.0		x	x		x	x	
120-1 AT	1.50	38.1	25.22	22.23	11.10	35.30	34.4	-	49.8	56.1	3.92	125 000	145 000	5.5		x	x		x	x	
140-1 AT	1.75	44.45	25.22	25.40	12.70	37.00	40.8	-	53.4	59.3	4.70	170 000	220 000	7.5		x	x		x	x	
160-1 AT	2.00	50.8	31.55	28.58	14.27	45.00	47.8	-	63.6	68.9	6.42	223 000	260 000	10.2		x	x		x	x	

* Loose parts are produced in Rexnord RexHiProAthletic® version

** Not compatible with straight sided plate roller chain

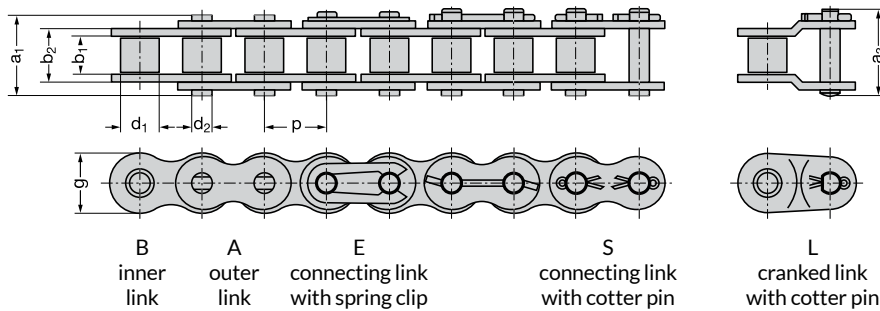

Chain No.	Pitch		Width between inner plates		Roller diameter	Pin diameter	Width over inner link	Plate depth	Transverse pitch	Pin length	Connecting pin length	Bearing area	Required minimum tensile strength DIN/ISO	Average tensile strength	Weight	Possible with straight sided plates	Loose parts				
	p		b ₁ min.	d ₁ max.	d ₂ max.	b ₂ max.	g	e	a ₁ max.	a ₃ max.	A	F _U	F _B	q	A		B	E*	L**	S*	
	Inch	mm	mm	mm	mm	mm	mm	mm	mm	mm	mm	cm ²	N	N	kg/m						
60-2 AT	0.75	19.05	12.57	11.91	5.94	17.70	17.8	22.78	48.5	51.5	2.10	62 600	80 000	3.0	x	x	x	x	x		
80-2 AT	1.00	25.4	15.75	15.88	7.92	22.50	23.6	29.29	62.4	57.1	3.56	111 200	150 000	5.2	x	x	x	x	x		
100-2 AT	1.25	31.75	18.90	19.05	9.53	27.40	29.2	35.76	75.3	87.8	5.22	174 000	220 000	8.0		x	x		x	x	
120-2 AT	1.50	38.1	25.22	22.23	11.10	35.30	34.4	45.44	95.3	101.6	7.84	250 000	290 000	11.0		x	x		x	x	
140-2 AT	1.75	44.45	25.22	25.40	12.70	37.00	40.8	48.87	103.3	109.6	9.40	340 000	440 000	14.9		x	x		x	x	
160-2 AT	2.00	50.8	31.55	28.58	14.27	45.00	47.8	58.55	122.1	130.1	12.84	446 000	490 000	20.2		x	x		x	x	

* Loose parts are produced in Rexnord RexHiProAthletic version

** Not compatible with straight sided plate roller chain

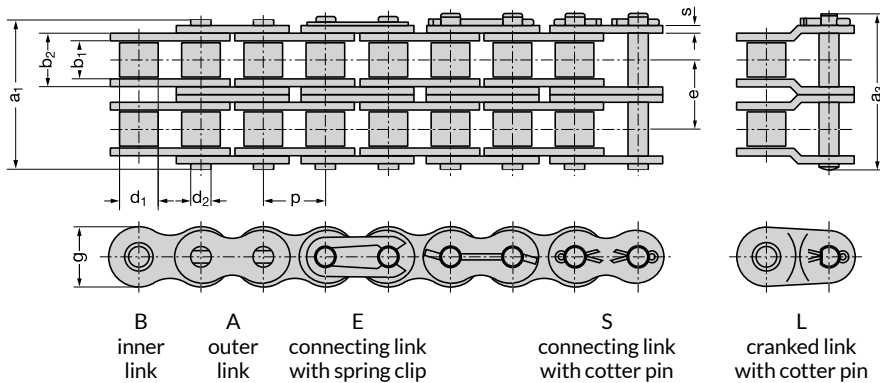

Chain No.	Pitch		Width between inner plates	Roller diameter	Pin diameter	Width over inner link	Plate depth	Transverse pitch		Pin length	Connecting pin length	Bearing area	Required minimum tensile strength DIN/ISO	Average tensile strength	Weight	Possible with straight sided plates	Loose parts			
	p	b ₁ min.	d ₁ max.	d ₂ max.	b ₂ max.	g	e	a ₁ max.	a ₃ max.	A	F _U	F _B	q	A	B		F*	S*		
	Inch	mm	mm	mm	mm	mm	mm	mm	mm	mm	cm ²	N	N	kg/m						
60-3 AT	0.75	19.05	12.57	11.91	5.94	17.70	17.8	22.78	72.6	77.2	3.15	93 900	120 000	4.5	x	x	x	x		
80-3 AT	1.00	25.4	15.75	15.88	7.92	22.50	23.6	29.29	91.9	97.3	5.35	166 800	220 000	7.8	x	x	x	x		
100-3 AT	1.25	31.75	18.90	19.05	9.53	27.40	29.2	35.76	111.1	117.2	7.83	261 000	300 000	12.0		x	x	x		
120-3 AT	1.50	38.1	25.22	22.23	11.10	35.30	34.4	45.44	140.7	148.3	11.75	375 000	450 000	16.5		x	x	x		
140-3 AT	1.75	44.45	25.22	25.40	12.70	37.00	40.8	48.87	151.2	158.5	14.10	510 000	660 000	22.3		x	x	x		
160-3 AT	2.00	50.8	31.55	28.58	14.27	45.00	47.8	58.55	180.7	188.7	19.26	669 000	730 000	30.3		x	x	x		

* Loose parts are produced in Rexnord RexHiProAthletic® version

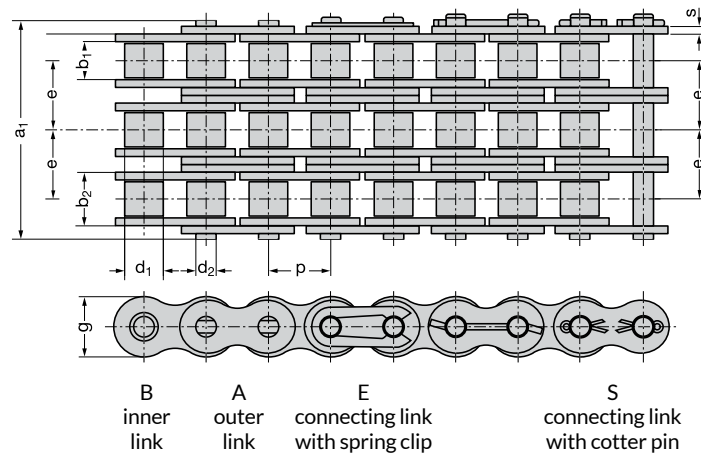



Rexnord® RexHiPro® Roller Chain

Extreme Performance

Rexnord RexHiPro Roller Chain provides very good **corrosion resistance** and features high dynamic loading capabilities, an extended wear life and high wear resistance.

Environmentally friendly

The Rexnord RexHiPro Roller Chain is environmentally friendly because it's completely free from chromium VI and heavy metals, silicone and Teflon. The chain lubrication has a NSF H2 certification and the chain is conform to RoHS:2011 standard (Directive 2011/65/EU) and Directive 2000/53/EC.

Excellent corrosion resistance

Another advantage of this chain is the excellent corrosion resistance. All chain parts have been coated with anti-corrosion substance which makes the resistance intact for over 600 hours.

Features

- Corrosion resistance over 600 hours (salt spray test conforms to ISO 9227)
- Tensile strength and long-term loading capacity comparable with Rexnord RexPro® Chain
- Dimensions in accordance with DIN, ANSI and ISO-Norm
- No process-related hydrogen embrittlement
- NSF H2 certification
- RoHS:2011 compliant for electronics industry
- Free from chromium VI, conform to guidelines 2011/65/EU, ROHS and Directive 2000/53/EC

Industries Served:

- Food & Beverage
- Agriculture
- Wood
- Material Handling

Long working life

The Rexnord RexHiPro Roller Chain is suitable for wet conditions and therefore can be used outdoors. It has an extremely long working life due to the anti-corrosion coating for all chain parts and the high strength and long-term loading capacity.

Advantages

- Corrosion-resistant
- Excellent resistance to liquids used in the automotive industry
- Long wear life
- Cost-effective

Lubrication

- Operating temperature: -30°C to +130°C
- With high temperature lubricants use is possible up to 250°C
- Use of Rexnord RexPro Lubrication, free from heavy metals, silicone and Teflon

Rexnord® RexHiPro® Roller Chain

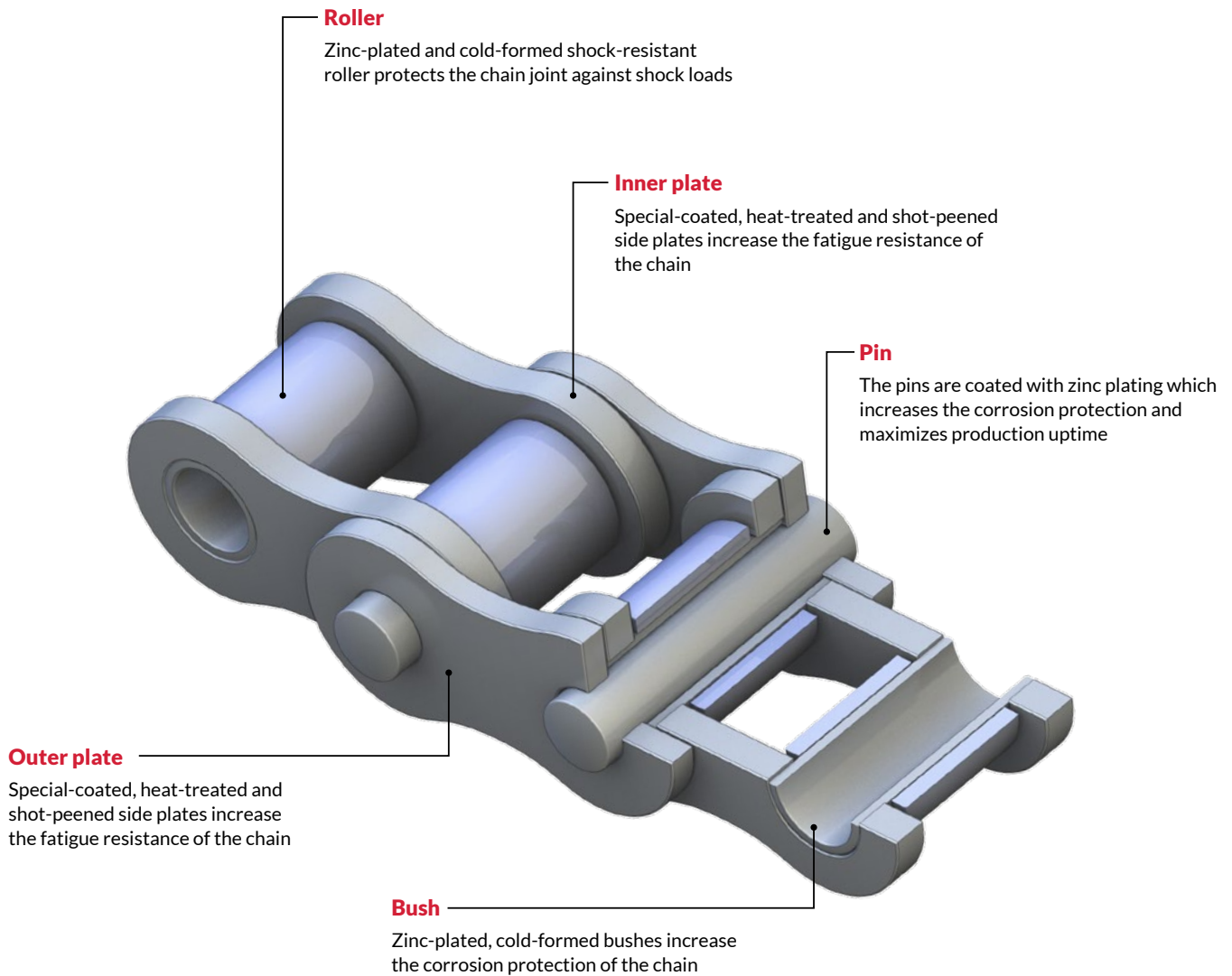

Loading capacity

- High loading capacity



Damp corrosion resistance

- Outstanding corrosion resistance
- Suitable for the Food & Beverage industry
- Ideal for outside applications



Wear resistance

- Servicing intervals as for Rexnord RexPro® Roller Chain
- Long service life



Eco-friendly

- NSF H2 certification
- Free of chromium VI

Chain No.*	Pitch		Width between inner plates		Roller diameter	Pin diameter	Width over inner link		Plate depth	Transverse pitch		Pin length	Connecting pin length	Bearing area	Required minimum tensile strength DIN/ISO	Average tensile strength	Weight	Possible with straight sided plates	Loose parts				
	p		b ₁ min.	d ₁ max.	d ₂ max.	b ₂ max.	ε	e	a ₁ max.	a ₃ max.	A	F _U	F _B	q	A	B	E**		L	S**			
	Inch	mm	mm	mm	mm	mm	mm	mm	mm	mm	mm	mm	mm	mm	cm ²	N	N		kg/m				
08 B - 1 HiPro	0.50	12.7	7.75	8.51	4.45	11.30	11.6	-	17.0	20.9	0.50	17 800	21 000	0.7	x	x	x	x	x				
10 B - 1 HiPro	0.625	15.875	9.65	10.16	5.08	13.28	14.6	-	19.6	23.7	0.67	22 200	25 000	0.9	x	x	x	x	x				
12 B - 1 HiPro	0.75	19.05	11.68	12.07	5.72	15.62	15.9	-	22.7	27.3	0.89	28 900	32 000	1.2	x	x	x	x	x				
16 B - 1 HiPro	1.00	25.40	17.02	15.88	8.28	25.40	20.5	-	36.1	41.5	2.10	60 000	80 000	2.7	x	x	x	x	x				
20 B - 1 HiPro	1.25	31.75	19.56	19.05	10.19	29.00	25.7	-	40.4	47.6	2.96	95 000	120 000	3.8	x	x	x		x	x			
24 B - 1 HiPro	1.50	38.10	25.40	25.40	14.63	37.90	33.0	-	53.8	60.6	5.54	160 000	211 000	7.0	x	x	x		x	x			
28 B - 1 HiPro	1.75	44.45	30.99	27.97	15.80	46.50	37.0	-	63.3	72.8	7.35	200 000	240 000	8.9		x	x		x	x			
32 B - 1 HiPro	2.00	50.80	30.99	29.21	17.81	45.50	41.2	-	65.1	73.6	8.10	250 000	315 000	9.9	x	x	x		x	x			

* Also available as triplex on request

** Loose parts are produced in Rexnord RexHiProAthletic® version

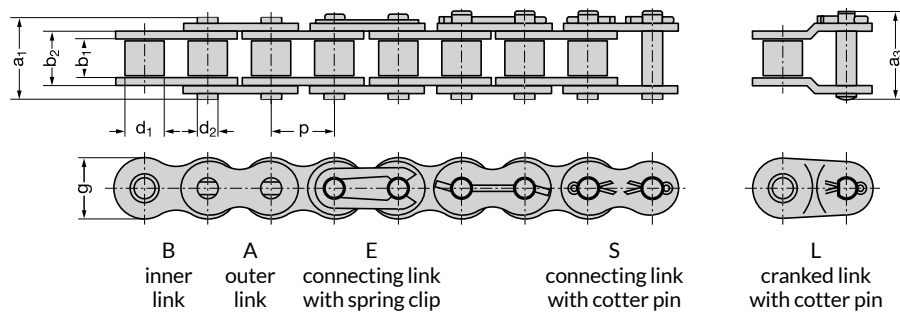

Chain No.*	Pitch		Width between inner plates		Roller diameter	Pin diameter	Width over inner link		Plate depth	Transverse pitch		Pin length	Connecting pin length	Bearing area	Required minimum tensile strength DIN/ISO	Average tensile strength	Weight	Possible with straight sided plates	Loose parts				
	p		b ₁ min.	d ₁ max.	d ₂ max.	b ₂ max.	ε	e	a ₁ max.	a ₃ max.	A	F _U	F _B	q	A	B	E**		L	S**			
	Inch	mm	mm	mm	mm	mm	mm	mm	mm	mm	mm	mm	mm	mm	cm ²	N	N		kg/m				
08 B - 2 HiPro	0.50	12.7	7.75	8.51	4.45	11.30	11.6	13.92	30.6	34.9	1.01	31 100	43 000	1.4	x	x	x	x	x				
10 B - 2 HiPro	0.625	15.875	9.65	10.16	5.08	13.28	14.6	16.59	35.5	40.3	1.35	44 500	50 000	1.8	x	x	x	x	x				
12 B - 2 HiPro	0.75	19.05	11.68	12.07	5.72	15.62	15.9	19.46	41.7	46.8	1.79	57 800	64 000	2.3	x	x	x	x	x				
16 B - 2 HiPro	1.00	25.4	17.02	15.88	8.28	25.40	20.5	31.88	67.4	73.4	4.21	106 000	140 000	5.3	x	x	x	x	x				
20 B - 2 HiPro	1.25	31.75	19.56	19.05	10.19	29.00	25.7	36.45	76.9	83.6	5.91	170 000	230 000	7.5	x	x	x		x	x			
24 B - 2 HiPro	1.50	38.1	25.40	25.40	14.63	37.90	33.0	48.36	102.2	122.7	11.09	280 000	370 000	13.7	x	x	x		x	x			
28 B - 2 HiPro	1.75	44.45	30.99	27.97	15.80	46.50	37.0	59.56	122.8	132.7	14.69	360 000	480 000	17.8		x	x		x	x			
32 B - 2 HiPro	2.00	50.8	30.99	29.21	17.81	45.50	41.2	58.55	123.6	132.4	16.21	450 000	530 000	19.6	x	x	x		x	x			

* Also available as triplex on request

** Loose parts are produced in Rexnord RexHiProAthletic version

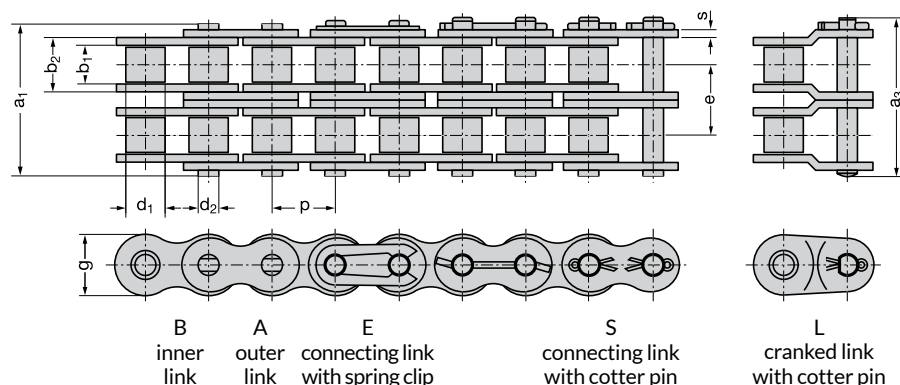

Chain No.*	Pitch		Width between inner plates		Roller diameter	Pin diameter	Width over inner link		Plate depth	Transverse pitch		Pin length	Connecting pin length	Bearing area	Required minimum tensile strength DIN / ISO	Average tensile strength	Weight	Possible with straight sided plates					Loose parts					
	p		b ₁ min.	d ₁ max.	d ₂ max.	b ₂ max.	g	e	a ₁ max.	a ₃ max.	A	F _U	F _B	q														
	Inch	mm	mm	mm	mm	mm	mm	mm	mm	mm	mm	mm	mm	mm	cm ²	N	N	kg/m	A	B	E**	L***	S**	A	B	E**	L***	S**
60-1 HiPro	0.75	19.05	12.57	11.91	5.94	17.70	17.8	-	25.7	28.6	1.05	31 300	40 000	1.5	x	x	x	x	x	x	x	x	x	x	x	x	x	x
80-1 HiPro	1.00	25.4	15.75	15.88	7.92	22.50	23.6	-	33.0	38.0	1.78	55 600	65 000	2.6	x	x	x	x	x	x	x	x	x	x	x	x	x	x
100-1 HiPro	1.25	31.75	18.90	19.05	9.53	27.40	29.2	-	39.4	44.9	2.61	87 000	105 000	4.0				x	x			x	x			x	x	
120-1 HiPro	1.50	38.1	25.22	22.23	11.10	35.30	34.4	-	49.8	56.1	3.92	125 000	145 000	5.5				x	x			x	x			x	x	
140-1 HiPro	1.75	44.45	25.22	25.40	12.70	37.00	40.8	-	53.4	59.3	4.70	170 000	220 000	7.5				x	x			x	x			x	x	
160-1 HiPro	2.00	50.8	31.55	28.58	14.27	45.00	47.8	-	63.6	68.9	6.42	223 000	260 000	10.2				x	x			x	x			x	x	

* Also available as triplex on request
 ** Loose parts are produced in Rexnord RexHiProAthletic® version
 *** Not compatible with straight sided plate roller chain

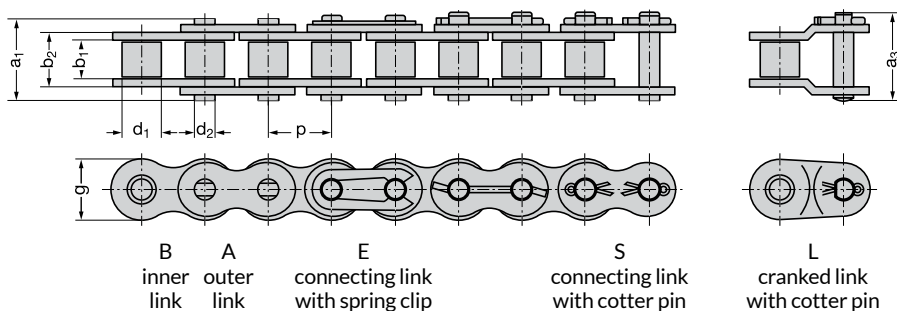

RexHiPro

Chain No.*	Pitch		Width between inner plates		Roller diameter	Pin diameter	Width over inner link		Plate depth	Transverse pitch		Pin length	Connecting pin length	Bearing area	Required minimum tensile strength DIN / ISO	Average tensile strength	Weight	Possible with straight sided plates					Loose parts					
	p		b ₁ min.	d ₁ max.	d ₂ max.	b ₂ max.	g	e	a ₁ max.	a ₃ max.	A	F _U	F _B	q														
	Inch	mm	mm	mm	mm	mm	mm	mm	mm	mm	mm	mm	mm	mm	cm ²	N	N	kg/m	A	B	E**	L***	S**	A	B	E**	L***	S**
60-2 HiPro	0.75	19.05	12.57	11.91	5.94	17.70	17.8	22.78	48.5	51.5	2.10	62 600	80 000	3.0	x	x	x	x	x	x	x	x	x	x	x	x	x	x
80-2 HiPro	1.00	25.4	15.75	15.88	7.92	22.50	23.6	29.29	62.4	57.1	3.56	111 200	150 000	5.2	x	x	x	x	x	x	x	x	x	x	x	x	x	x
100-2 HiPro	1.25	31.75	18.90	19.05	9.53	27.40	29.2	35.76	75.3	87.8	5.22	174 000	220 000	8.0				x	x			x	x			x	x	
120-2 HiPro	1.50	38.1	25.22	22.23	11.10	35.30	34.4	45.44	95.3	101.6	7.84	250 000	290 000	11.0				x	x			x	x			x	x	
140-2 HiPro	1.75	44.45	25.22	25.40	12.70	37.00	40.8	48.87	103.3	109.6	9.40	340 000	440 000	14.9				x	x			x	x			x	x	
160-2 HiPro	2.00	50.8	31.55	28.58	14.27	45.00	47.8	58.55	122.1	130.1	12.84	446 000	490 000	20.2				x	x			x	x			x	x	

* Also available as triplex on request
 ** Loose parts are produced in Rexnord RexHiProAthletic version
 *** Not compatible with straight sided plate roller chain

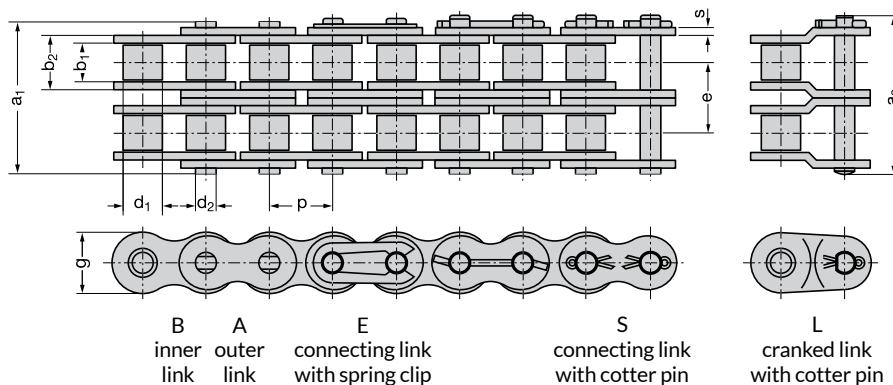



Rexnord® RexHiProAthletic® Roller Chain

Extreme Performance

Rexnord RexHiProAthletic Roller Chain is a combination of Rexnord RexHiPro® and RexAthletic® chain types. It provides the very good **corrosion resistance** of the RexHiPro and the **high wear resistance** of the RexAthletic.

Long-term corrosion resistance

Every single part of the Rexnord RexHiProAthletic Roller Chain has a special corrosion-resistant coating.

High loading capability

Thanks to the improved protection against chain joint stiffness and the high fatigue resistance, the Rexnord RexHiProAthletic Roller Chain has a high loading capability. The chain is ideal for heavy loading applications in rough environments.

Low maintenance

The chain requires low maintenance thanks to the high performance and the long-term lubrication. This makes the Rexnord RexHiProAthletic Chain ideal for applications where maintenance and lubrication possibilities are restricted.

Industries Served:

- Food & Beverage
- Agriculture
- Wood
- Material Handling

Features

- Outstanding tribological characteristics
- Excellent sliding properties
- Fatigue resistance and chain traction comparable with Rexnord High Performance chain
- Anti-corrosion coating for all chain parts.
- Improved protection against chain joint stiffness
- NSF H1 certification for the food industry
- Chain sizes with pitch from 12.7 mm to 50.8 mm available (special sizes on request)
- Dimensions in accordance with DIN, ANSI and ISO standards

Advantages

- Reduced maintenance requirements and longer lubrication intervals
- Excellent corrosion resistance
- High wear resistance even with inadequate lubrication
- Long service life under tough loading conditions

Application

- Where maintenance and lubrication possibilities are restricted
- High loads under difficult conditions
- Wet and outdoor usage
- Food, beverage, and packaging industries
- Amusement parks
- Agriculture and forestry machinery
- Enclosed systems

Rexnord® RexHiProAthletic® Roller Chain

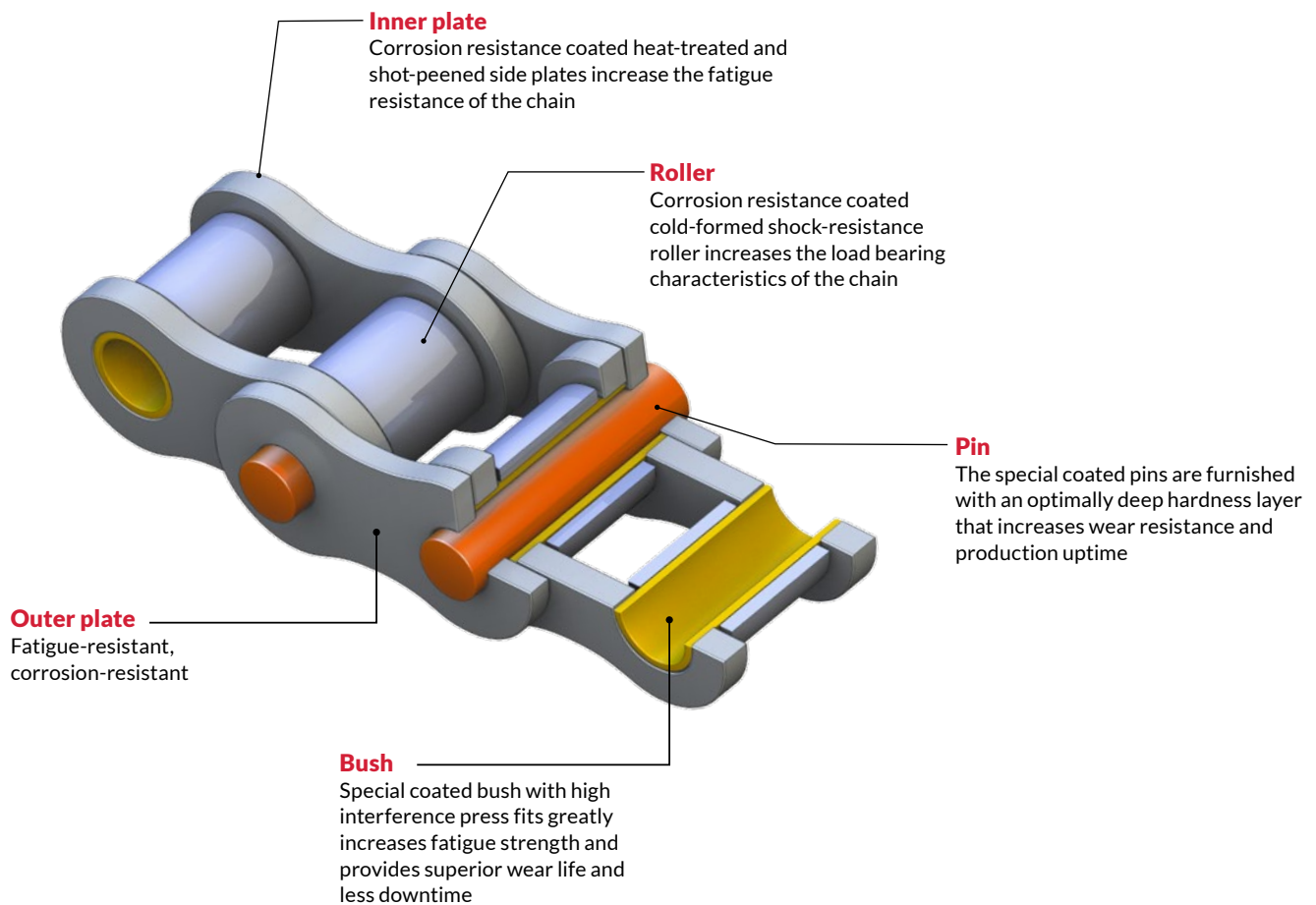

Loading capacity

- High loading capacity



Wear resistance

- Low maintenance
- Extremely long service life
- Good emergency running properties



Eco-friendly

- Less relubrication necessary
- Free of chromium VI
- NSF H1 certification



Damp corrosion resistance

- Outstanding corrosion resistance
- Suitable for the food & beverage industry
- Ideal for outside applications

 This product meets the requirements of Machine Directive 2006/42/EC

Chain No.	Pitch		Width between inner plates	Roller diameter	Pin diameter	Width over inner link	Plate depth	Transverse pitch	Pin length	Connecting pin length	Bearing area	Required minimum tensile strength DIN / ISO	Average tensile strength	Weight	Possible with straight sided plates	Loose parts				
	p		b ₁ min.	d ₁ max.	d ₂ max.	b ₂ max.	g	e	a ₁ max.	a ₃ max.	A	F _u	F _b	q		A	B	E*	L	S*
	Inch	mm	mm	mm	mm	mm	mm	mm	mm	mm	mm	cm ²	N	N		kg/m				
08 B - 1 HiProAT	0.50	12.7	7.75	8.51	4.45	11.30	11.6	-	17.0	20.9	0.50	17 800	21 000	0.7	x	x	x	x	x	
10 B - 1 HiProAT	0.625	15.875	9.65	10.16	5.08	13.28	14.6	-	19.6	23.7	0.67	22 200	25 000	0.9	x	x	x	x	x	
12 B - 1 HiProAT	0.75	19.05	11.68	12.07	5.72	15.62	15.9	-	22.7	27.3	0.89	28 900	32 000	1.2	x	x	x	x	x	
16 B - 1 HiProAT	1.00	25.40	17.02	15.88	8.28	25.40	20.5	-	36.1	41.5	2.10	60 000	80 000	2.7	x	x	x	x	x	
20 B - 1 HiProAT	1.25	31.75	19.56	19.05	10.19	29.00	25.7	-	40.4	47.6	2.96	95 000	120 000	3.8	x	x	x		x	x
24 B - 1 HiProAT	1.50	38.10	25.40	25.40	14.63	37.90	33.0	-	53.8	60.6	5.54	160 000	211 000	7.0	x	x	x		x	x
28 B - 1 HiProAT	1.75	44.45	30.99	27.97	15.80	46.50	37.0	-	63.3	72.8	7.35	200 000	240 000	8.9		x	x		x	x
32 B - 1 HiProAT	2.00	50.80	30.99	29.21	17.81	45.50	41.2	-	65.1	73.6	8.10	250 000	315 000	9.9	x	x	x		x	x

* Loose parts are produced in Rexnord RexHiProAthletic version

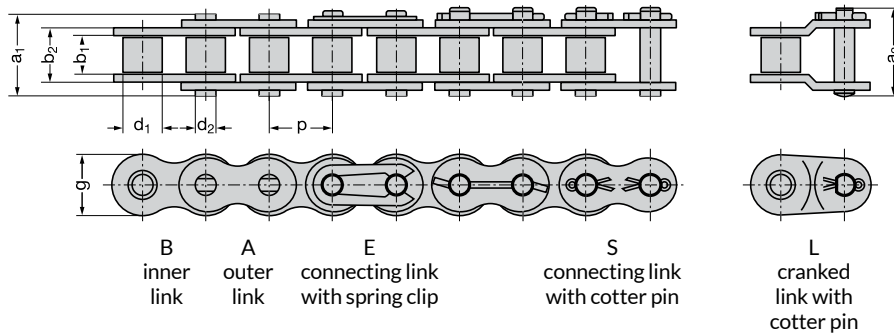

Chain No.	Pitch		Width between inner plates	Roller diameter	Pin diameter	Width over inner link	Plate depth	Transverse pitch	Pin length	Connecting pin length	Bearing area	Required minimum tensile strength DIN / ISO	Average tensile strength	Weight	Possible with straight sided plates	Loose parts				
	p		b ₁ min.	d ₁ max.	d ₂ max.	b ₂ max.	g	e	a ₁ max.	a ₃ max.	A	F _u	F _b	q		A	B	E*	L	S*
	Inch	mm	mm	mm	mm	mm	mm	mm	mm	mm	mm	cm ²	N	N		kg/m				
08 B - 2 HiProAT	0.50	12.7	7.75	8.51	4.45	11.30	11.6	13.92	30.6	34.9	1.01	31 100	43 000	1.4	x	x	x	x	x	
10 B - 2 HiProAT	0.625	15.875	9.65	10.16	5.08	13.28	14.6	16.59	35.5	40.3	1.35	44 500	50 000	1.8	x	x	x	x	x	
12 B - 2 HiProAT	0.75	19.05	11.68	12.07	5.72	15.62	15.9	19.46	41.7	46.8	1.79	57 800	64 000	2.3	x	x	x	x	x	
16 B - 2 HiProAT	1.00	25.4	17.02	15.88	8.28	25.40	20.5	31.88	67.4	73.4	4.21	106 000	140 000	5.3	x	x	x	x	x	
20 B - 2 HiProAT	1.25	31.75	19.56	19.05	10.19	29.00	25.7	36.45	76.9	83.6	5.91	170 000	230 000	7.5	x	x	x		x	x
24 B - 2 HiProAT	1.50	38.1	25.40	25.40	14.63	37.90	33.0	48.36	102.2	122.7	11.09	280 000	370 000	13.7	x	x	x		x	x
28 B - 2 HiProAT	1.75	44.45	30.99	27.97	15.80	46.50	37.0	59.56	122.8	132.7	14.69	360 000	480 000	17.8		x	x		x	x
32 B - 2 HiProAT	2.00	50.8	30.99	29.21	17.81	45.50	41.2	58.55	123.6	132.4	16.21	450 000	530 000	19.6	x	x	x		x	x

* Loose parts are produced in Rexnord RexHiProAthletic version

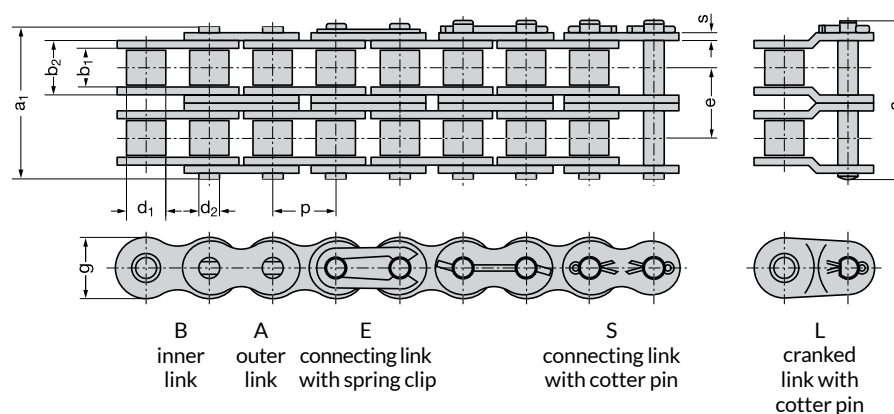

Chain No.	Pitch		Width between inner plates		Roller diameter	Pin diameter	Width over inner link		Plate depth	Transverse pitch		Pin length	Connecting pin length	Bearing area	Required minimum tensile strength DIN / ISO	Average tensile strength	Weight	Possible with straight sided plates					Loose parts					
	p		b ₁ min.	d ₁ max.	d ₂ max.	b ₂ max.	g	e	a ₁ max.	a ₃ max.	A	F _U	F _B	q														
	Inch	mm	mm	mm	mm	mm	mm	mm	mm	mm	mm	mm	mm	mm	cm ²	N	N	kg/m										
																			A	B	E*	L**	S*					
60 - 1 HiProAT	0.75	19.05	12.57	11.91	5.94	17.70	17.8	-	25.7	28.6	1.05	31 300	40 000	1.5	x	x	x	x	x	x	x	x						
80 - 1 HiProAT	1.00	25.4	15.75	15.88	7.92	22.50	23.6	-	33.0	38.0	1.78	55 600	65 000	2.6	x	x	x	x	x	x	x	x						
100 - 1 HiProAT	1.25	31.75	18.90	19.05	9.53	27.40	29.2	-	39.4	44.9	2.61	87 000	105 000	4.0				x	x			x	x					
120 - 1 HiProAT	1.50	38.1	25.22	22.23	11.10	35.30	34.4	-	49.8	56.1	3.92	125 000	145 000	5.5				x	x				x	x				
140 - 1 HiProAT	1.75	44.45	25.22	25.40	12.70	37.00	40.8	-	53.4	59.3	4.70	170 000	220 000	7.5				x	x					x	x			
160 - 1 HiProAT	2.00	50.8	31.55	28.58	14.27	45.00	47.8	-	63.6	68.9	6.42	223 000	260 000	10.2				x	x						x	x		

* Loose parts are produced in Rexnord RexHiProAthletic version
 ** Not compatible with straight sided plate roller chain

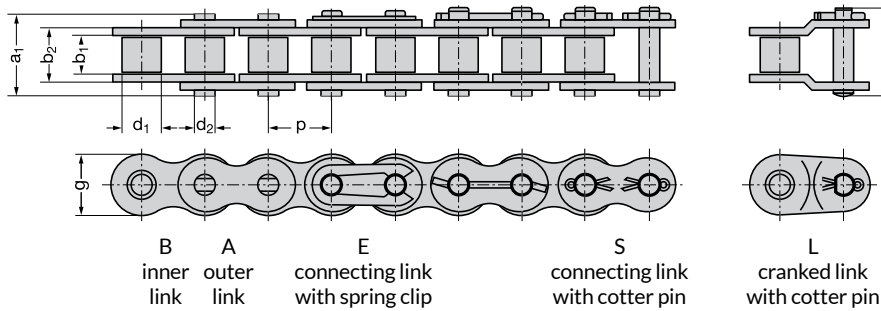

RexHiProAthletic

Chain No.	Pitch		Width between inner plates		Roller diameter	Pin diameter	Width over inner link		Plate depth	Transverse pitch		Pin length	Connecting pin length	Bearing area	Required minimum tensile strength DIN / ISO	Average tensile strength	Weight	Possible with straight sided plates					Loose parts					
	p		b ₁ min.	d ₁ max.	d ₂ max.	b ₂ max.	g	e	a ₁ max.	a ₃ max.	A	F _U	F _B	q														
	Inch	mm	mm	mm	mm	mm	mm	mm	mm	mm	mm	mm	mm	mm	cm ²	N	N	kg/m										
																			A	B	E*	L**	S*					
60 - 2 HiProAT	0.75	19.05	12.57	11.91	5.94	17.70	17.8	22.78	48.5	51.5	2.10	62 600	80 000	3.0	x	x	x	x	x	x	x	x						
80 - 2 HiProAT	1.00	25.4	15.75	15.88	7.92	22.50	23.6	29.29	62.4	57.1	3.56	111 200	150 000	5.2	x	x	x	x	x	x	x	x						
100 - 2 HiProAT	1.25	31.75	18.90	19.05	9.53	27.40	29.2	35.76	75.3	87.8	5.22	174 000	220 000	8.0				x	x				x	x				
120 - 2 HiProAT	1.50	38.1	25.22	22.23	11.10	35.30	34.4	45.44	95.3	101.6	7.84	250 000	290 000	11.0				x	x					x	x			
140 - 2 HiProAT	1.75	44.45	25.22	25.40	12.70	37.00	40.8	48.87	103.3	109.6	9.40	340 000	440 000	14.9				x	x						x	x		
160 - 2 HiProAT	2.00	50.8	31.55	28.58	14.27	45.00	47.8	58.55	122.1	130.1	12.84	446 000	490 000	20.2				x	x							x	x	

* Loose parts are produced in Rexnord RexHiProAthletic version
 ** Not compatible with straight sided plate roller chain

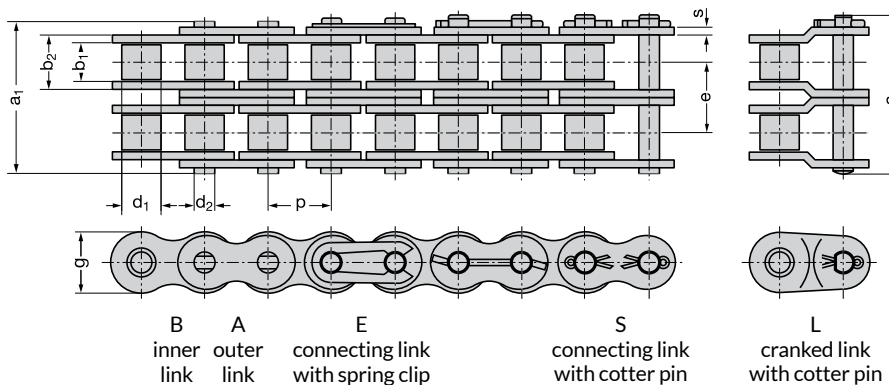

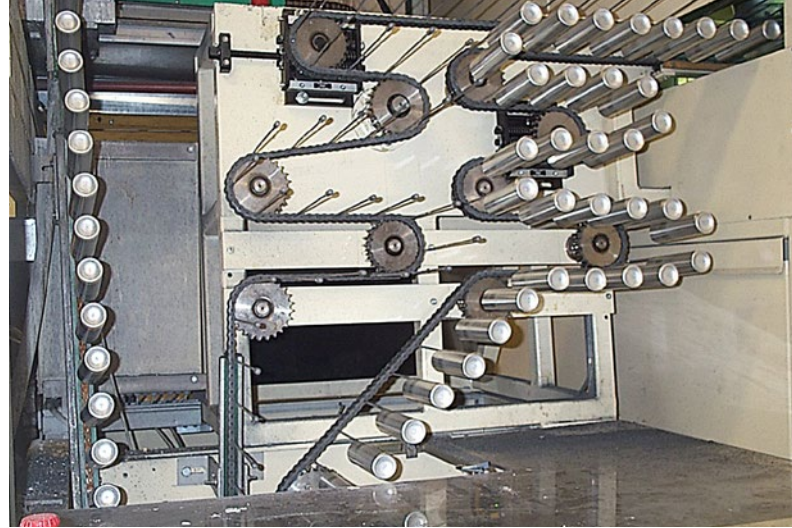

Rexnord® ReXtreme® Roller Chain

Extreme Performance

Rexnord ReXtreme Roller Chain is a **maintenance-free roller chain for special applications**. Certain treatments and synthetic high performance ex-works lubrication provide very good sliding characteristics for maintenance-free operations.

Maintenance-free

Due to the high performance and long-term lubrication the need for maintenance and relubrication is not necessary anymore. This is ideal in case the maintenance and lubrication possibilities are limited. A special coating in the chain joint offers excellent sliding characteristics.

Long wear life

Even with minimum lubrication and especially for conveyor applications the Rexnord ReXtreme Roller Chain can be used maintenance-free. The chain contains improved protection against stiff joints and links.

Features

- Outstanding tribological characteristics
- Excellent sliding properties
- High fatigue strength and chain traction comparable with Rexnord High Performance Chain
- Improved protection against chain joint stiffness
- Chain sizes with pitch from 12.7 millimeter (mm) to 25.4 mm available (special sizes on request)
- Corrosion resistance over 120 hours (salt spray test conforms to DIN EN ISO 9227)
- No process-related hydrogen embrittlement
- Free of chromium VI: conform to guidelines 2011/65/EU, ROHS and Directive 2000/53/EC
- Dimensions in accordance with DIN, ANSI and ISO standards

Industries Served:

- Automotive
- Tube Transport
- General Mechanical Engineering

Very good corrosion resistance

Another advantage of this chain is the outstanding corrosion resistance. The chain has been coated with anti-corrosion substance which makes the resistance intact for over 120 hours.

Special lubrication

The special Rexnord ReXtreme Lubrication is approved for conveyor and oven chains in painting areas as well as for all other applications in the car body paint shop.

Advantages

- Extremely long service life, even without relubrication
- Due to the optimal ex-works lubrication, no contamination of conveyed goods and surrounding area occurs
- A good price-performance ratio
- High energy efficiency

Lubrication

- High performance and high temperature synthetic lubricant
- Temperature range from -5°C to +250°C
- Free of silicone
- Especially developed for automotive painting application
- Paint compatible lubrication

Rexnord® ReXtreme® Roller Chain

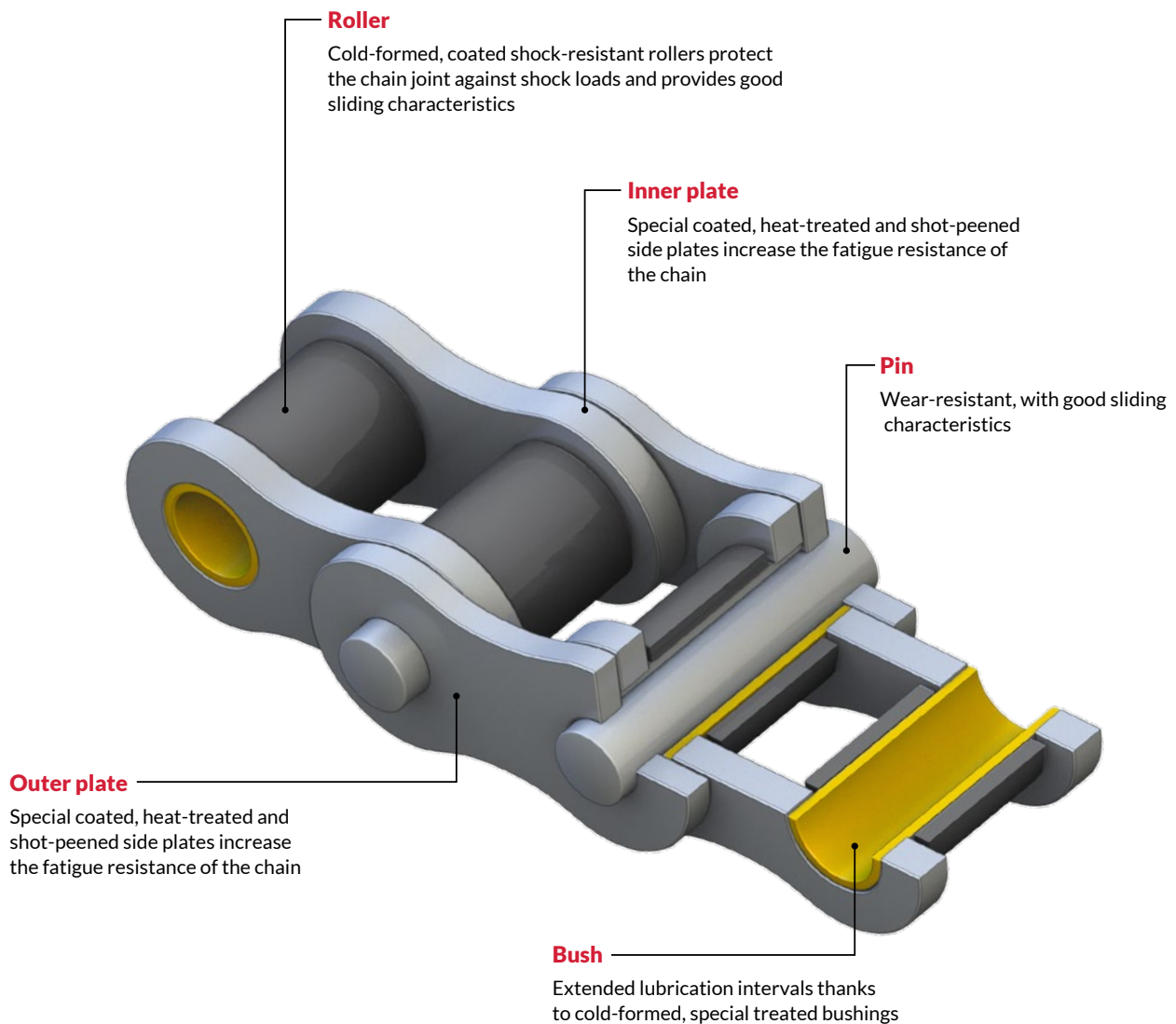

Loading capacity

- High loading capacity under high temperature



Wear resistance

- Maintenance-free
- Extremely long service life
- Ideal where maintenance and lubrication possibilities are restricted



Eco-friendly

- No relubrication necessary
- Free of chromium VI

Recommended chain tractive power for appropriate speeds*

Chain No.	Temperature range from -5°C to +120°C admissible tractive power for			Temperature range +120°C to +250°C admissible tractive power for		
	N up to 0,25 m/s	N up to 0,5 m/s	N up to 1,0 m/s	N up to 0,25 m/s	N up to 0,5 m/s	N up to 1,0 m/s
08 B - 1 XT	850	600	450	500	400	300
10 B - 1 XT	1200	850	600	700	550	400
12 B - 1 XT	1500	1100	800	800	700	500
16 B - 1 XT	3500	2700	1900	2100	1600	1100
08 B - 2 XT	1400	1000	700	800	700	500
10 B - 2 XT	2100	1400	1000	1200	900	700
12 B - 2 XT	2600	1900	1400	1500	1200	800
16 B - 2 XT	6100	4700	3300	3600	2500	1900

* Valid for minimum sprocket center distance of 1500 mm and based on 21-tooth sprockets

Chain No.*	Pitch		Width between inner plates		Roller diameter	Pin diameter	Width over inner link		Plate depth	Transverse pitch		Pin length	Connecting pin length	Bearing area	Required minimum tensile strength DIN / ISO	Average tensile strength	Weight	Possible with straight sided plates	Loose parts				
	p		b ₁ min.	d ₁ max.	d ₂ max.	b ₂ max.	g	e	a ₁ max.	a ₃ max.	A	F _U	F _B	q	A	B	E**		L	S**			
	Inch	mm	mm	mm	mm	mm	mm	mm	mm	mm	mm	mm	mm	cm ²							N	N	kg/m
08 B - 1XT	0.50	12.7	7.75	8.51	4.45	11.30	11.6	-	16.7	20.9	0.50	17 800	21 000	0.7	x	x	x	x	x				
10 B - 1XT	0.625	15.875	9.65	10.16	5.08	13.28	14.6	-	18.9	23.7	0.67	22 200	25 000	0.9	x	x	x	x	x				
12 B - 1XT	0.75	19.05	11.68	12.07	5.72	15.62	15.9	-	22.3	27.3	0.89	28 900	32 000	1.2	x	x	x	x	x				
16 B - 1XT	1.00	25.40	17.02	15.88	8.28	25.40	20.5	-	35.4	41.5	2.10	60 000	80 000	2.7	x	x	x	x	x				

* Larger sizes available on request

** Loose parts are produced in Rexnord RexHiProAthletic® version

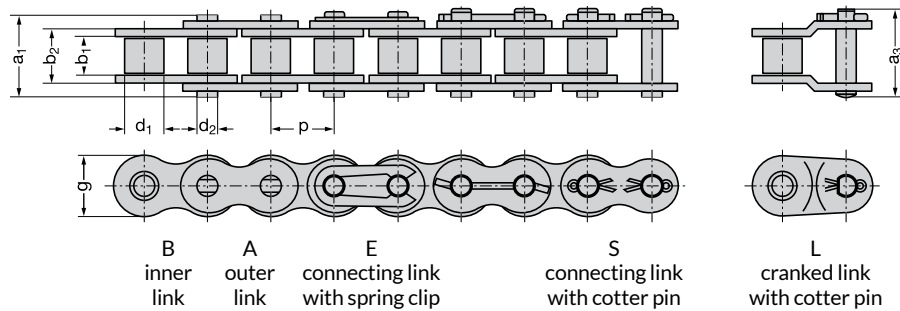

Chain No.*	Pitch		Width between inner plates		Roller diameter	Pin diameter	Width over inner link		Plate depth	Transverse pitch		Pin length	Connecting pin length	Bearing area	Required minimum tensile strength DIN / ISO	Average tensile strength	Weight	Possible with straight sided plates	Loose parts				
	p		b ₁ min.	d ₁ max.	d ₂ max.	b ₂ max.	g	e	a ₁ max.	a ₃ max.	A	F _U	F _B	q	A	B	E**		L	S**			
	Inch	mm	mm	mm	mm	mm	mm	mm	mm	mm	mm	mm	mm	mm							cm ²	N	N
08 B - 2XT	0.50	12.7	7.75	8.51	4.45	11.30	11.6	13.92	30.6	34.9	1.01	31 100	43 000	1.4	x	x	x	x	x				
10 B - 2XT	0.625	15.875	9.65	10.16	5.08	13.28	14.6	16.59	35.5	40.3	1.35	44 500	50 000	1.8	x	x	x	x	x				
12 B - 2XT	0.75	19.05	11.68	12.07	5.72	15.62	15.9	19.46	41.7	46.8	1.79	57 800	64 000	2.3	x	x	x	x	x				
16 B - 2XT	1.00	25.4	17.02	15.88	8.28	25.40	20.5	31.88	67.4	73.4	4.21	106 000	140 000	5.3	x	x	x	x	x				

* Larger sizes available on request

** Loose parts are produced in Rexnord RexHiProAthletic version

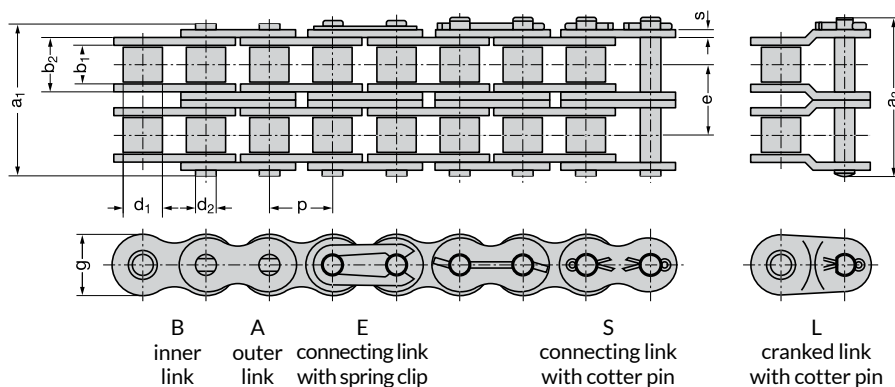



Rexnord® RexCarbon® Roller Chain

Extreme Performance

Rexnord RexCarbon **maintenance-free** Roller Chain contains RexCarbon sliding sleeves that require no relubrication. This chain produces less noise compared to sinterbush chain.

Maintenance-free

The high-tech thermoplastic bushes in the Rexnord RexCarbon Roller Chain take over the function of lubrication. Thanks to the low friction in the chain link, no maintenance is needed. You won't experience any downtime in your production cycle.

High wear resistance

The chain is very robust, it contains case hardened pins and the sliding surface of the chain joint itself has wear-minimizing characteristics. Together with the low friction in the chain link, this results in a high wear resistance of the chain.

Features

- Outstanding tribological characteristics
- High wear resistance
- High-tech carbon sliding sleeves
- Extremely robust
- NSF H1 certification
- Low-friction chain bearing
- Relubrication is not required although it reduces friction in the application

Industries Served:

- Automotive
- Food & Beverage
- Cosmetics / Pharmacy
- Packaging Industry

Improved safety

The Rexnord RexCarbon Roller Chain makes it possible to create an extra safe and clean working environment since there is no lubrication needed.

Environmentally friendly

The chain is environmentally friendly since there is no relubrication needed. It's completely free of silicone and Teflon and differentiates itself by its low-noise running.

Advantages

- Extremely long service life, even without relubrication
- No machine downtime for relubrication
- Low-noise and eco-friendly
- High energy efficiency

Lubrication

- With food-grade ex-works lubrication
- Temperature range from -40°C to +120°C
- For temperatures from +120°C to +175°C please consult Regal Rexnord™ Engineering
- A paint-compatible lubrication is available upon request

Rexnord® RexCarbon® Roller Chain

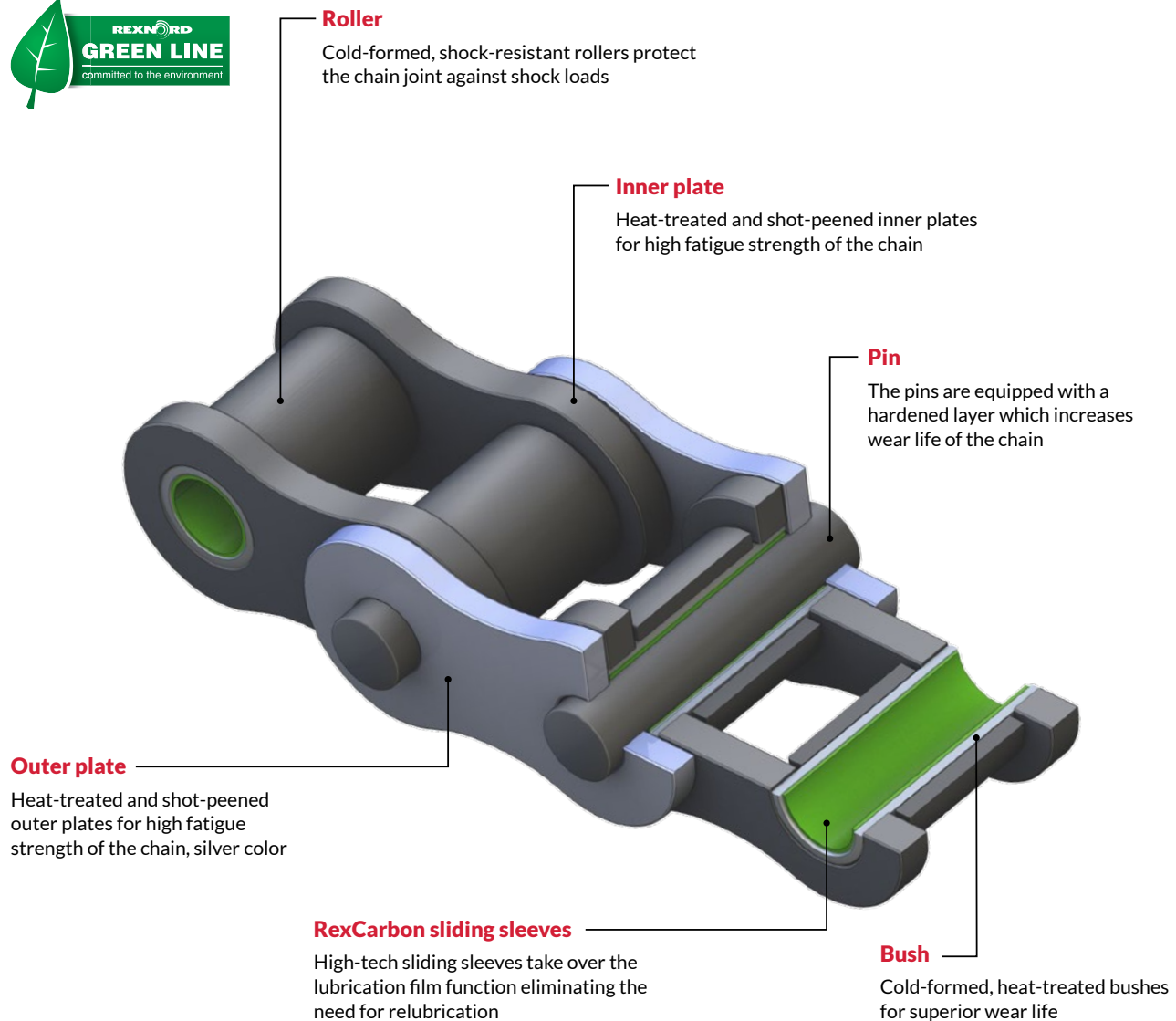

Loading capacity

- Ideal for critical conditions



Wear resistance

- Maintenance-free
- Extremely long service life
- Very good wear resistance properties



Eco-friendly

- No relubrication necessary
- Low-noise
- Ex-works lubrication with NSF H1 certification

Recommended chain tractive power for appropriate speeds

Chain No.	Temperature range from -40°C to +80°C admissible tractive power for				Temperature range +80°C to +120°C* admissible tractive power for	
	N up to 0,5 m/s	N up to 1,0 m/s	N up to 1,5 m/s	N up to 2,0 m/s	N up to 0,5 m/s	N up to 1,0 m/s
08 B - 1 CB	850	750	650	500	680	600
10 B - 1 CB	1100	1000	900	670	880	800
12 B - 1 CB	1500	1300	1100	890	1200	1040
16 B - 1 CB	3500	3100	2700	2100	2800	2480
08 B - 2 CB	1500	1300	1100	900	1200	1000
10 B - 2 CB	1900	1800	1600	1200	1500	1400
12 B - 2 CB	2600	2300	1900	1600	2100	1800
16 B - 2 CB	6100	5400	4700	3700	4900	4300

Based on 21-tooth sprockets

* For temperatures above +120°C please consult Regal Rexnord™ Engineering (available up to +175°C)

Chain No.	Pitch		Width between inner plates	Roller diameter	Pin diameter	Width over inner link	Plate depth	Transverse pitch	Pin length	Connecting pin length	Bearing area	Average tensile strength	Weight	Straight sided plate	Loose parts		
	p		b_1 min.	d_1 max.	d_2 max.	b_2 max.	g	e	a_1 max.	a_3 max.	A	F_B	q		A	B	E
	Inch	mm	mm	mm	mm	mm	mm	mm	mm	mm	mm	cm ²	N		kg/m		
08 B - 1CB	0.50	12.7	7.75	8.51	4.45	11.30	11.6	-	16.7	20.0	0.50	17 000	0.70		x	x	x
10 B - 1CB	0.625	15.875	9.65	10.16	5.08	13.28	13.8	-	18.9	23.7	0.67	20 000	0.90	x	x	x	x
12 B - 1CB	0.75	19.05	11.68	12.07	5.72	15.62	15.9	-	22.3	27.3	0.89	31 500	1.15	x	x	x	x
16 B - 1CB	1.00	25.4	17.02	15.88	8.28	25.40	20.5	-	35.4	41.5	2.10	64 500	2.60	x	x	x	x

* Deviated ultimate tensile strength and chain length tolerance (up to +0.3%)

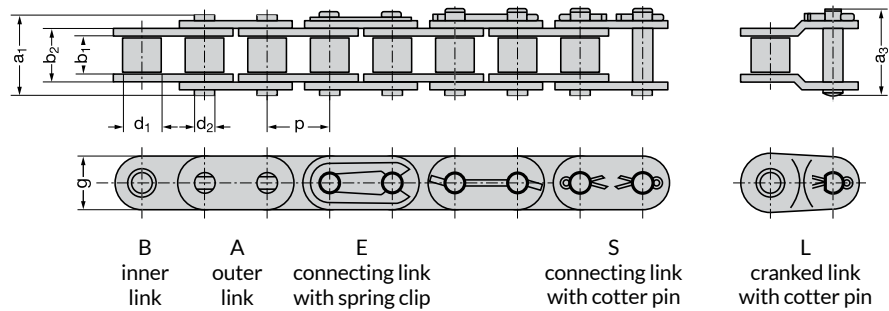

Chain No.	Pitch		Width between inner plates	Roller diameter	Pin diameter	Width over inner link	Plate depth	Transverse pitch	Pin length	Connecting pin length	Bearing area	Average tensile strength	Weight	Straight sided plate	Loose parts		
	p		b_1 min.	d_1 max.	d_2 max.	b_2 max.	g	e	a_1 max.	a_3 max.	A	F_B	q		A	B	E
	Inch	mm	mm	mm	mm	mm	mm	mm	mm	mm	mm	cm ²	N		kg/m		
08 B - 2CB	0.50	12.7	7.75	8.51	4.45	11.30	11.6	13.92	30.6	34.9	1.01	31 500	1.4		x	x	x
10 B - 2CB	0.625	15.875	9.65	10.16	5.08	13.28	13.8	16.59	35.5	40.3	1.35	40 000	1.8	x	x	x	x
12 B - 2CB	0.75	19.05	11.68	12.07	5.72	15.62	15.9	19.46	41.7	46.8	1.79	63 000	2.3	x	x	x	x
16 B - 2CB	1.00	25.4	17.02	15.88	8.28	25.40	20.5	31.88	67.4	73.4	4.21	118 500	5.3	x	x	x	x

* Deviated ultimate tensile strength and length intolerance (up to +0.3%)

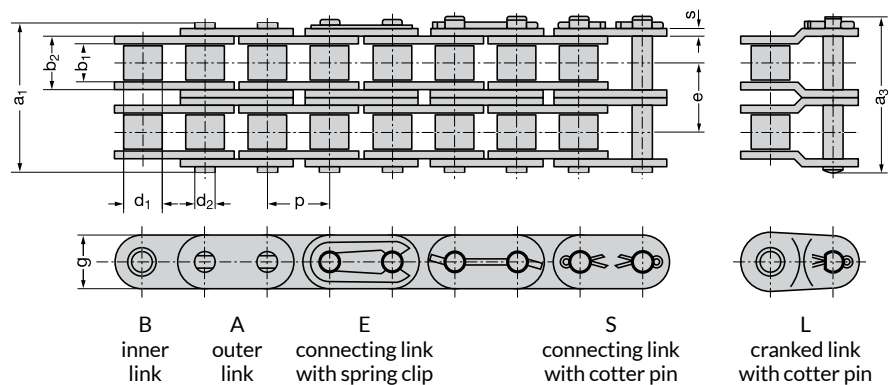

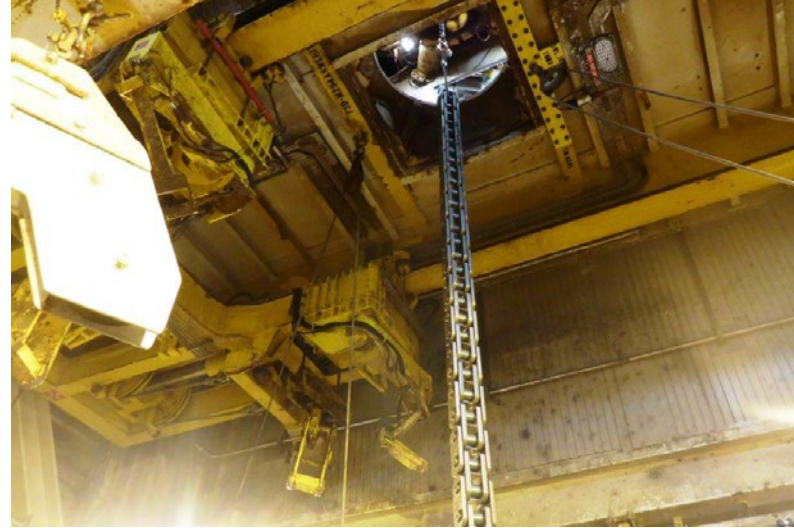

Rexnord® RexProX® Roller Chain

Extreme Performance

Rexnord RexProX **load-resistant** Roller Chain provides high static and dynamic loading capabilities and reliabilities. Therefore a long wear life, high breaking load and fatigue resistance is granted.

Environmentally friendly

The chain contains no heavy metals, no Teflon or silicone. This results in an environmentally friendly product that is DIN EN ISO 14001 certified.

Extreme high fatigue resistance

The Rexnord RexProX Roller Chain is very robust, even in difficult conditions. It has an extremely high impact strength due to calibrated plates, reinforced chain links and the seamless rollers. Through Rexnord RexPro Lubrication the chain is protected. All these factors result in an extreme high fatigue resistance.

Features

- Enlarged bearing area
- Improved tensile strength
- Outstanding fatigue resistance
- Compatible with European types

Advantages

- For high-performance power transmission
- Very high impact strength
- Extremely robust, even under difficult conditions

High loading capacity

In situations where heavy drives and lifting applications are needed, this chain is ideal. It has a high loading capacity in combination with maximum operational safety.

Industries Served:

- Mining & Metals
- Cement & Aggregate
- Forestry
- Agriculture
- Logistics & Transportation
- Construction

Rexnord® RexProX® Roller Chain

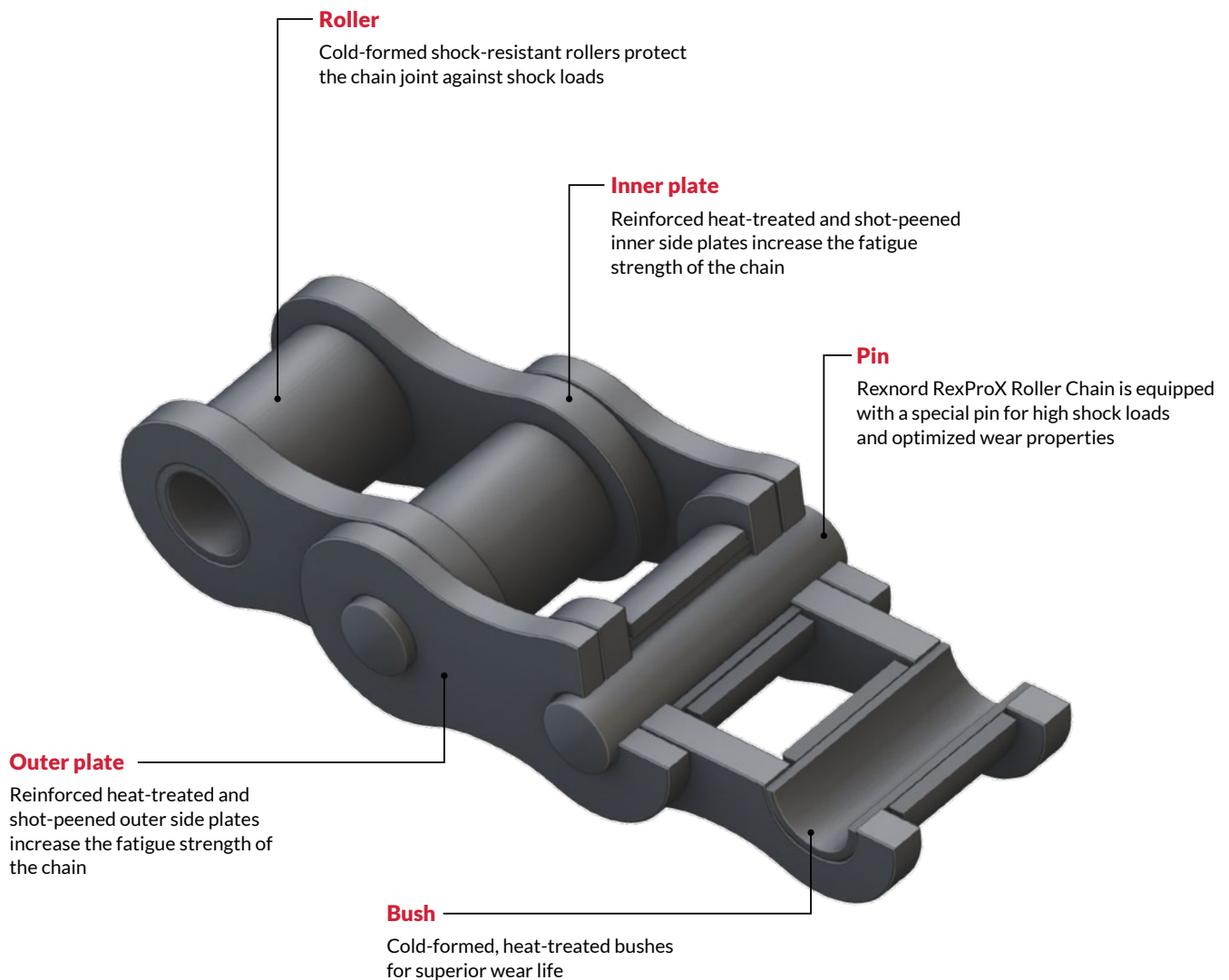

Loading capacity

- For the heavy-duty drives and lifting purposes
- Extremely high loading capacity
- Highest tensile strength
- High impact resistance



Wear resistance

- High protection through Rexnord RexPro® Lubrication
- Extremely robust
- Long service life
- High operational reliability
- Excellent resistance to wear due to heat treatment and enlarged bearing area of parts subject to wear.



Eco-friendly

- Use of Rexnord RexPro Lubrication, contains no heavy metals and is Silicone- and Teflon-free
- Environment management system conforms to DIN EN ISO 14001

 This product meets the requirements of Machine Directive 2006/42/EC

Chain No.*	Pitch	Width between inner plates		Roller diameter	Pin diameter	Width over inner link	Plate depth	Transverse pitch	Pin length	Connecting pin length	Bearing area	Minimum tensile strength	Average tensile strength	Weight	Straight sided plate	Loose parts					
	p	b ₁ min.	d ₁ max.	d ₂ max.	b ₂ max.	g	-	a ₁ max.	a ₃ max.	A	F _U	F _B	q	A		B	C	E	L	S	
	Inch	mm	mm	mm	mm	mm	mm	-	mm	mm	cm ²	N	N	kg/m							
Re 480	0.75	19.05	11.68	12.07	6.10	17.23	16.8	-	25.0	29.5	1.05	40 000	50 000	1.5	x	x		x	x	x	
KRV 12	1.00	25.4	12.70	19.05	10.19	25.70	24.0	-	40.1	45.5	2.62	117 500	140 000	4.4	x	x				x	
R 25 - 1SH	1.00	25.4	17.02	15.88	8.28	25.40	24.0	-	35.4	38.5	2.10	85 000	100 000	3.2	x	x	x		x	x	
R 31 - 1SH	1.25	31.75	19.56	19.05	10.19	32.00	29.2	-	45.8	49.6	3.26	150 000	170 000	5.3	x	x				x	
R 38 - 1SH	1.50	38.10	25.40	25.40	14.63	40.00	36.2	-	56.7	63.3	5.85	235 000	250 000	8.7	x	x				x	
R 44 - 1SH	1.75	44.45	30.99	27.97	15.90	46.50	40.8	-	66.3	73.7	7.39	270 000	300 000	10.4	x	x				x	
R 50 - 1SH	2.00	50.8	30.99	29.21	17.81	45.50	47.8	-	66.5	75.0	8.10	385 000	415 000	11.5	x	x				x	

* Also available in larger sizes and as triplex on request

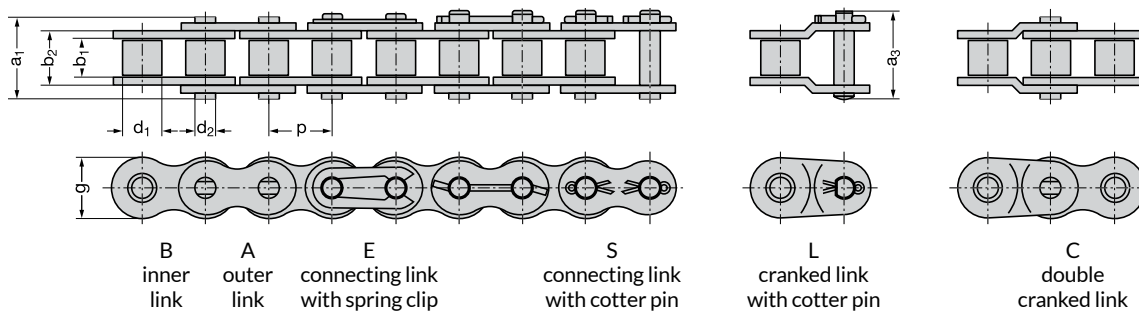

Rexnord RexProX Roller Chain for heavy-duty drives and lifting purposes

Duplex roller chain

Chain No.*	Pitch	Width between inner plates		Roller diameter	Pin diameter	Width over inner link	Plate depth	Transverse pitch	Pin length	Connecting pin length	Bearing area	Minimum tensile strength	Average tensile strength	Weight	Straight sided plate	Loose parts					
	p	b ₁ min.	d ₁ max.	d ₂ max.	b ₂ max.	g	e	a ₁ max.	a ₃ max.	A	F _U	F _B	q	A		B	C	E	L	S	
	Inch	mm	mm	mm	mm	mm	mm	mm	mm	mm	mm	cm ²	N	N		kg/m					
R 25 - 2SH	1.00	25.40	17.02	15.88	8.28	25.40	24.0	31.88	67.4	70.7	4.21	170 000	190 000	6.4	x	x	x		x	x	
R 31 - 2SH	1.25	31.75	19.56	19.05	10.19	32.00	29.2	42.00	87.8	91.6	6.52	260 000	300 000	10.4	x	x				x	
R 38 - 2SH	1.50	38.10	25.40	25.40	14.63	40.00	36.2	52.00	108.7	115.3	11.70	450 000	500 000	17.0	x	x	x			x	
R 44 - 2SH	1.75	44.45	30.99	27.97	15.90	46.50	40.8	61.20	127.5	134.9	14.79	465 000	525 000	20.5	x	x				x	
R 50 - 2SH	2.00	50.80	30.99	29.21	17.81	45.50	47.8	60.20	126.7	135.2	16.21	650 000	725 000	22.5	x	x				x	

* Also available in larger sizes and as triplex on request

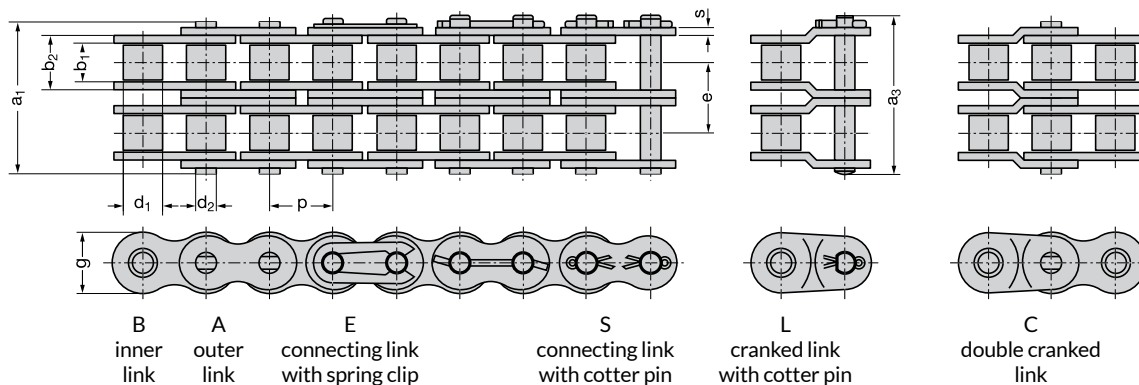



Rexnord® RexPlus® Roller Chain

Extreme Performance

Rexnord RexPlus Roller Chain provides outstanding **wear resistance** and very good **acid and corrosion protection**.

Rust- and acid-resistant

The Rexnord RexPlus Roller Chain consists of extremely rust- and acid-resistant materials. This makes it possible to use the chain in water, steam and aggressive liquids without damaging the chain. At the same time, due to the heat-treatment of the pins, the wear life of this chain is significantly longer than other corrosion-resistant chains. A stability list is available upon request.

Maximum hygiene

Where strict hygienic conditions or water is a factor and corrosion-free material is needed, Rexnord RexPlus Roller Chain offers superior performance. Direct food contact is permitted. This makes it the best choice for the Food & Beverage industry.

Long service life

A long service life is granted due to the special steel used in the chain. Together with the heat-treated pin, this steel ensures a high wear resistance and long wear lifetime.

Features

- Made from materials with excellent rust- and acid-resistant properties
- High loading capacity at speeds up to approximately 1.5 meter / second
- Seamless bushes
- NSF H1 certification
- Link plates made of RexPlus special steel
- High mechanical stability
- Perfect to use in extreme conditions

Advantages

- High wear resistance
- Hygienic
- Resistant to water and steam
- Direct contact with foodstuffs permitted
- Long service life

Lubrication

- With food-grade lubricant
- Temperature range: -40°C to +120°C (extension from +120°C to +400°C possible)
- Also available without ex-works lubrication

Industries Served:

- Food & Beverage
- Pulp & Paper
- Material Handling

Rexnord® RexPlus® Roller Chain

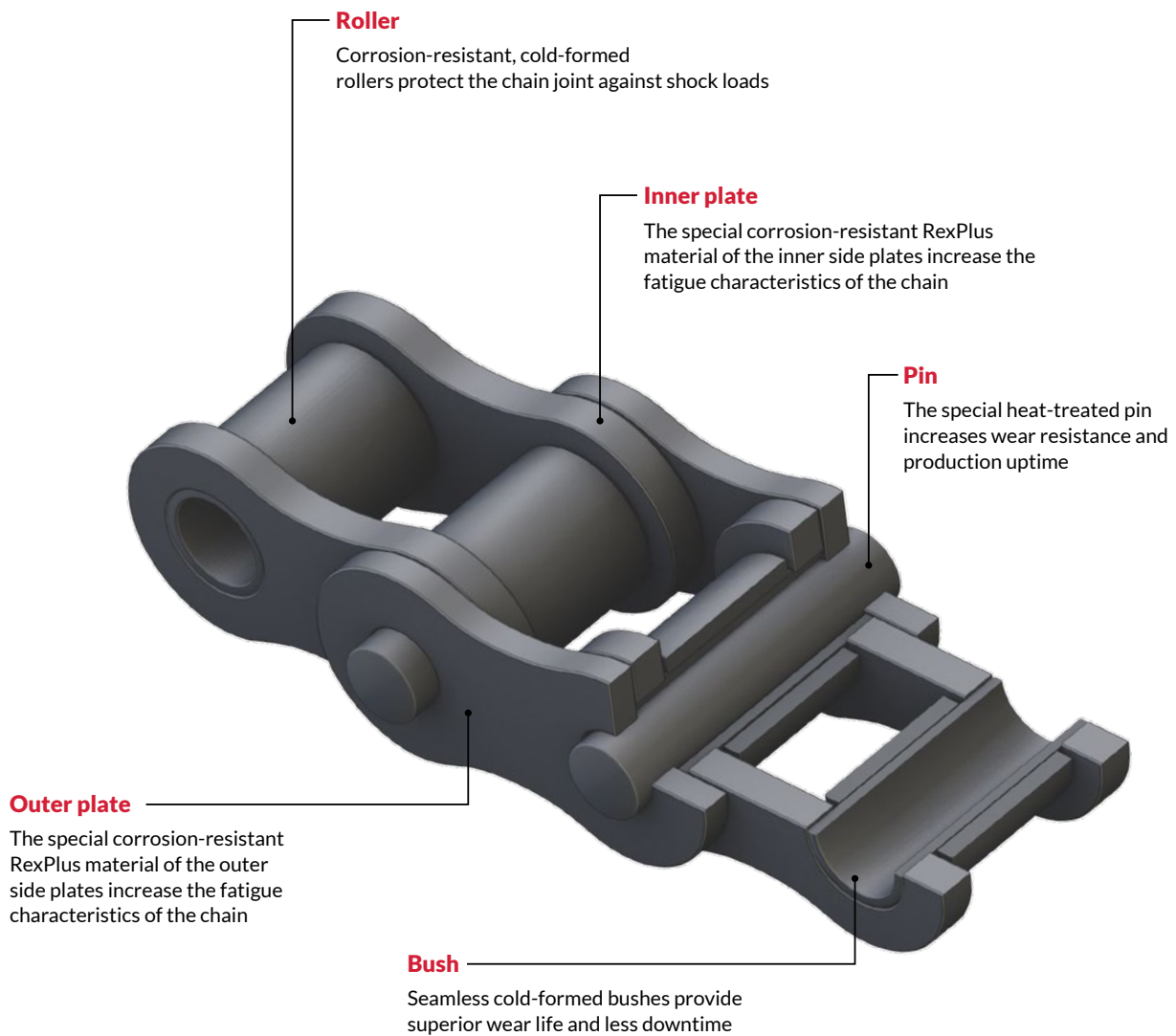

Wear resistance

- Long service life
- Highly reliable



Eco-friendly

- NSF H1 certification



Damp corrosion resistance

- Water and steam
- Fulfills hygiene requirements



Acid corrosion resistance

- For extreme conditions
- Excellent resistance to acids and aggressive liquids



This product meets the requirements of Machine Directive 2006/42/EC

Recommended chain tractive power for appropriate speeds

Chain No.	Temperature range -40°C to +200°C admissible tractive power for				Temperature range +200°C to +400°C admissible tractive power for	
	N up to 0,5 m/s	N up to 1,0 m/s	N up to 1,5 m/s	N up to 2,0 m/s	N up to 0,5 m/s	N up to 1,0 m/s
08 B - 1 SS	850	750	650	500	530	470
10 B - 1 SS	1100	1000	900	670	690	630
12 B - 1 SS	1500	1300	1100	890	940	810
16 B - 1 SS	3500	3100	2700	2100	2200	1900
08 B - 2 SS	1500	1300	1100	900	900	800
10 B - 2 SS	1900	1800	1600	1200	1200	1100
12 B - 2 SS	2600	2300	1900	1600	1600	1400
16 B - 2 SS	6100	5400	4700	3700	3800	3400
08 B - 3 SS	2100	1900	1600	1300	1300	1200
10 B - 3 SS	2800	2500	2300	1700	1800	1600
12 B - 3 SS	3800	3300	2800	2200	2400	2100
16 B - 3 SS	8800	7800	6800	5300	5500	4900

Based on 21-tooth sprockets

Chain No.	Pitch		Width between inner plates	Roller diameter	Pin diameter	Width over inner link	Plate depth	Transverse pitch	Pin length	Connecting pin length	Bearing area	Average tensile strength	Weight	Possible with straight sided plates	Loose parts					
	p	b ₁ min.	d ₁ max.	d ₂ max.	b ₂ max.	g	e	a ₁ max.	a ₃ max.	A	F _B	q	A		B	C*	E	L*	S	
	Inch	mm	mm	mm	mm	mm	mm	mm	mm	mm	cm ²	N	kg/m							
08 B - 1 SS	0.50	12.7	7.75	8.51	4.45	11.30	11.6	-	16.7	19.0	0.50	12 000	0.7		x	x	x	x	x	
10 B - 1 SS	0.625	15.875	9.65	10.16	5.08	13.28	14.6	-	18.9	22.0	0.67	15 500	0.9	x	x	x	x	x	x	
12 B - 1 SS	0.75	19.05	11.68	12.07	5.72	15.62	15.9	-	22.3	25.1	0.89	17 500	1.15	x	x	x	x	x	x	x
16 B - 1 SS	1.00	25.4	17.02	15.88	8.28	25.40	20.8	-	35.4	40.8	2.10	44 000	2.6	x	x	x	x	x	x	

* Cranked links only available in standard approved austenitic stainless steel

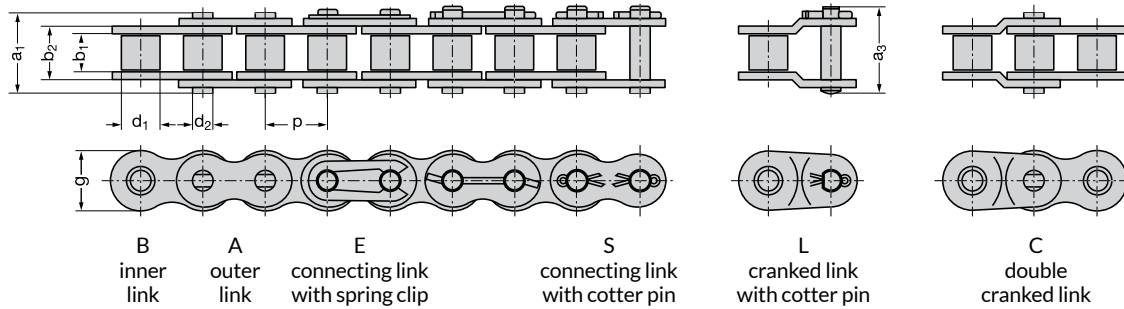

Chain No.	Pitch		Width between inner plates	Roller diameter	Pin diameter	Width over inner link	Plate depth	Transverse pitch	Pin length	Connecting pin length	Bearing area	Average tensile strength	Weight	Possible with straight sided plates	Loose parts					
	p	b ₁ min.	d ₁ max.	d ₂ max.	b ₂ max.	g	e	a ₁ max.	a ₃ max.	A	F _B	q	A		B	C*	E	L*		
	Inch	mm	mm	mm	mm	mm	mm	mm	mm	mm	cm ²	N	kg/m							
08 B - 2 SS	0.5	12.7	7.75	8.51	4.45	11.30	11.6	13.92	31.0	33.0	1.01	22 200	1.4		x	x	x	x	x	
10 B - 2 SS	0.625	15.875	9.65	10.16	5.08	13.28	14.6	16.59	35.5	38.6	1.35	31 000	1.8	x	x	x	x	x	x	
12 B - 2 SS	0.75	19.05	11.68	12.07	5.72	15.62	15.9	19.46	41.7	44.4	1.79	35 000	2.3	x	x	x	x	x	x	
16 B - 2 SS	1	25.4	17.02	15.88	8.28	25.40	20.8	31.88	67.4	72.8	4.21	81 000	5.3	x	x	x	x	x	x	

* Cranked links only available in standard approved austenitic stainless steel

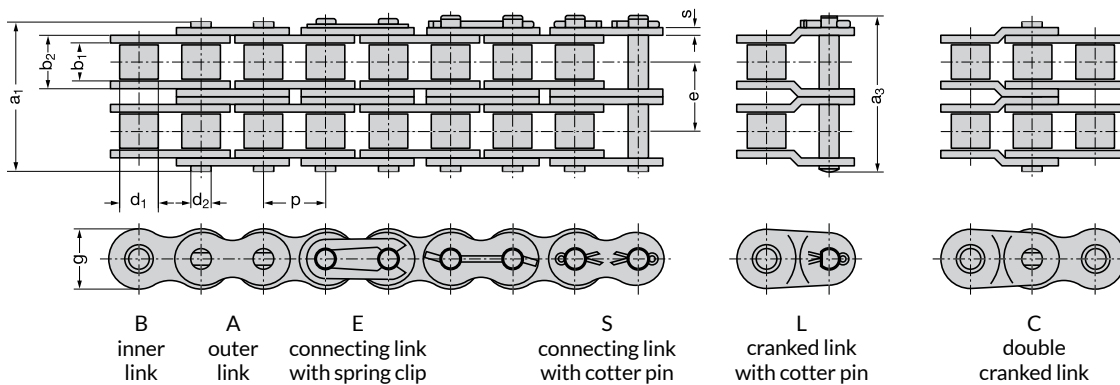

Chain No.	Pitch		Width between inner plates	Roller diameter	Pin diameter	Width over inner link	Plate depth	Transverse pitch	Pin length	Connecting pin length	Bearing area	Average tensile strength	Weight	Possible with straight sided plates	Loose parts				
	p		b_1 min.	d_1 max.	d_2 max.	b_2 max.	g	e	a_1 max.	a_3 max.	A	F_B	q		A	B	E		
	Inch	mm	mm	mm	mm	mm	mm	mm	mm	mm	mm	mm	mm		cm ²	N	kg/m	x	x
08 B - 3 SS	0.50	12.7	7.75	8.51	4.45	11.30	11.6	13.92	44.6	47.2	1.51	32 400	2.1	x	x	x	x	x	x
10 B - 3 SS	0.625	15.875	9.65	10.16	5.08	13.28	14.6	16.59	52.2	55.6	2.02	46 500	2.6	x	x	x	x	x	x
12 B - 3 SS	0.75	19.05	11.68	12.07	5.72	15.62	15.9	19.46	61.3	65.2	2.68	52 500	3.4	x	x	x	x	x	x
16 B - 3 SS	1.00	25.4	17.02	15.88	8.28	25.40	20.5	31.88	9.3	107.2	6.31	119 000	7.8	x	x	x	x	x	x

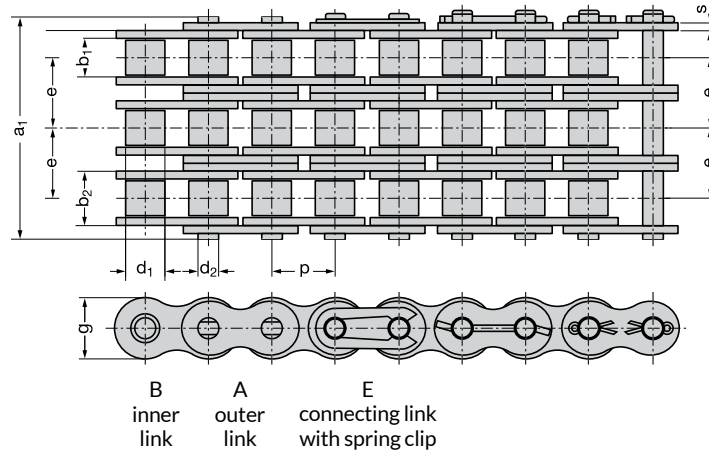

Side bow roller chain – Rexnord RexPlus Roller Chain made of stainless steel

Simplex roller chain

Chain No.	Pitch		Width between inner plates	Roller diameter	Pin diameter	Width over inner link	Plate depth	Pin length	Radius	Minimum tensile strength	Weight	Loose parts		
	p		b_1 min.	d_1 max.	d_2 max.	b_2 max.	g	a_1 max.	R min.	F_B	q	A	B	E
	Inch	mm	mm	mm	mm	mm	mm	mm	mm	N	kg/m	x	x	x
843 SS	0.50	12.7	7.80	7.92	3.96	11.0	11.6	17.9	1000	11 000	0.7	x	x	
63 SS	0.75	19.05	12.80	11.91	5.08	17.6	16.8	29.1	356	14 000	1.4			

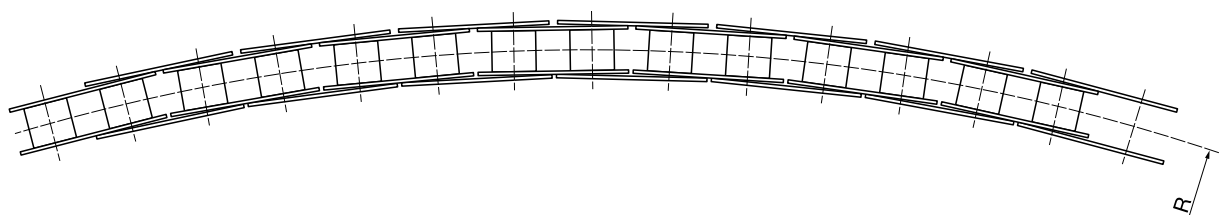
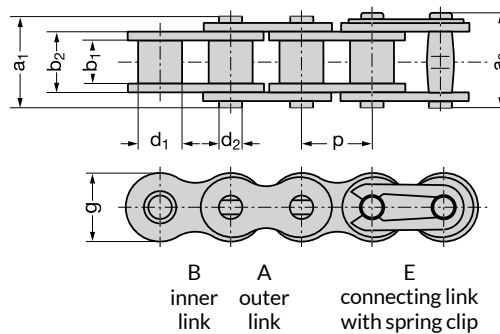



Rexnord® RexPlusCarbon® Roller Chain

Extreme Performance

Rexnord RexPlusCarbon **maintenance-free** Roller Chain contains excellent **acid- and corrosion-resistant** thermoplastic sliding sleeves, that require no relubrication. This chain features an extreme long wear life and high wear resistance.

Maintenance-free

The high-tech thermoplastic bushes in the Rexnord RexPlusCarbon Roller Chain take over the function of lubrication. Thanks to the low friction in the chain link, no maintenance is needed. You won't experience any downtime in your production cycle.

Maximum hygiene

Where strict hygienic conditions or water is a factor and corrosion-free material is needed, Rexnord RexPlus Roller Chain offers superior performance. Direct food contact is permitted. This makes it the best choice for the Food & Beverage industry.

Rust- and acid-resistant

The Rexnord RexPlus Roller Chain consists of extremely rust- and acid-resistant materials. This makes it possible to use the chain in water, steam and aggressive liquids without damaging the chain. At the same time, due to the heat-treatment of the pins, the wear life of this chain is significantly longer than other corrosion-resistant chains. A stability list is available upon request.

Environmentally friendly

The chain is environmentally friendly since there is no relubrication needed. This results in a more efficient and eco-friendly way of producing. Next to this, the chain has a very high energy efficiency and is low-noise. Thanks to its environmentally friendly properties, the chain is NSF H1 certified. It's completely free of silicone and Teflon.

Industries Served:

- Food & Beverage
- Automotive
- Material Handling

Features

- Long lifetime
- Rust- and acid-resistant
- Optimized wear properties
- NSF H1 certification
- High-tech RexCarbon sliding sleeves
- Link plates made of RexPlus special steel

Advantages

- Reduced downtime, no relubrication required
- No contamination of conveyed goods and surroundings, as no relubrication is needed
- Easy cleaning
- Hygienic
- Low-noise and environmentally friendly
- Energy-efficient

Lubrication

- Food-grade lubricant
- Temperature range from -40°C to +120°C
- Special versions suitable for temperatures up to +175°C (Please contact Regal Rexnord™ Engineering)

Rexnord® RexPlusCarbon® Roller Chain

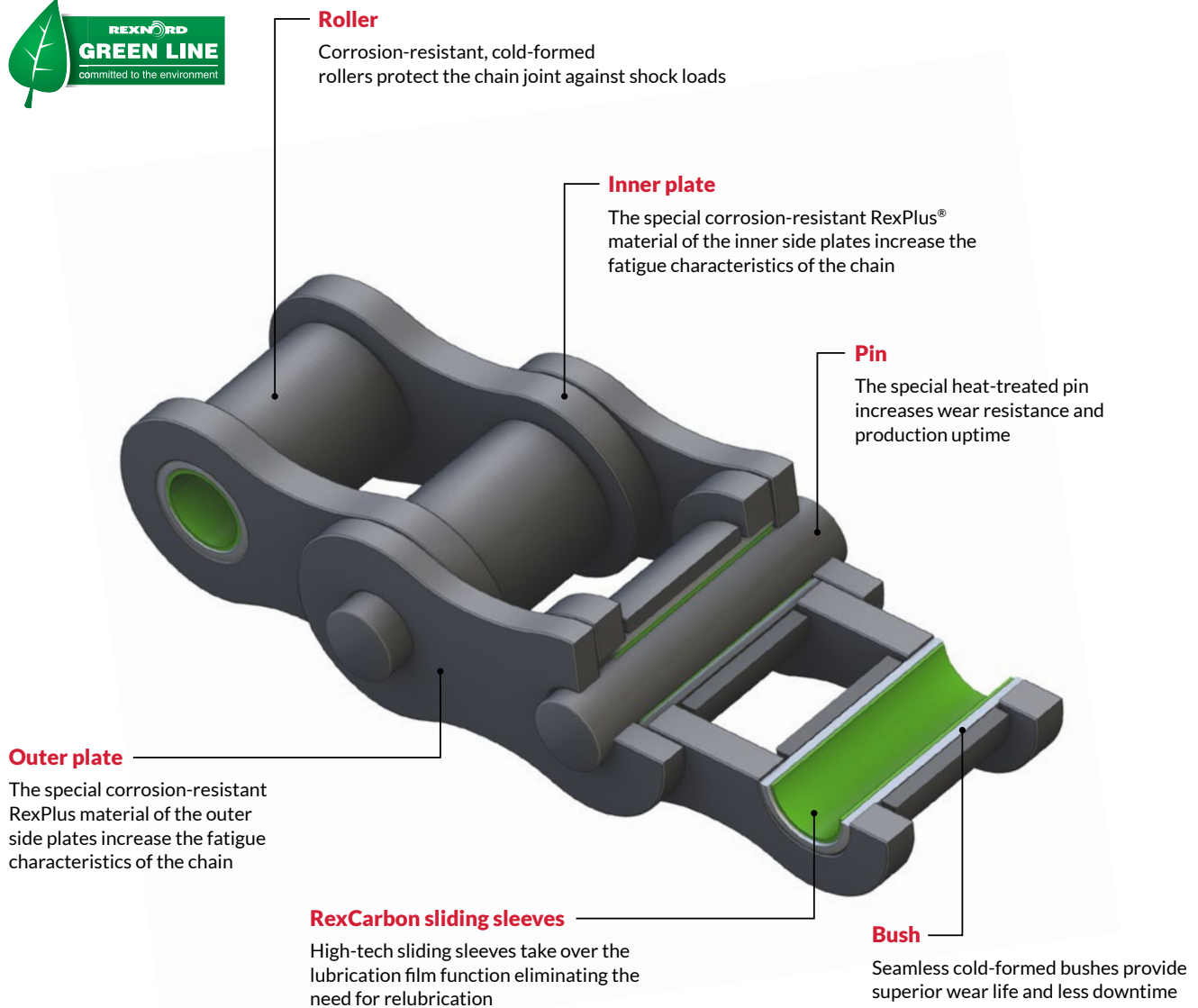

Wear resistance

- Maintenance-free
- Continuous high loading capacity



Damp corrosion resistance

- Multifunctional but specifically suitable for critical applications
- Hygienic
- Excellent resistance to rust and acids



Eco-friendly

- NSF H1 certification
- No relubrication required



This product meets the requirements of Machine Directive 2006/42/EC

Recommended chain tractive power for appropriate speeds

Chain No.	Temperature range from -40° C to +80° C admissible tractive power for				Temperature range +80° C to +120° C admissible tractive power for *	
	N up to 0,5 m/s	N up to 1,0 m/s	N up to 1,5 m/s	N up to 2,0 m/s	N up to 0,5 m/s	N up to 1,0 m/s
08 B - 1 SS CB	850	750	650	500	680	600
10 B - 1 SS CB	1100	1000	900	670	880	800
12 B - 1 SS CB	1500	1300	1100	890	1200	1040
16 B - 1 SS CB	3500	3100	2700	2100	2800	2480
08 B - 2 SS CB	1500	1300	1100	900	1200	1000
10 B - 2 SS CB	1900	1800	1600	1200	1500	1400
12 B - 2 SS CB	2600	2300	1900	1600	2100	1800
16 B - 2 SS CB	6100	5400	4700	3700	4900	4300

Based on 21-tooth sprockets

* For temperatures above +120°C please consult Regal Rexnord™ Engineering (available up to +175°C)

Chain No.	Pitch		Width between inner plates	Roller diameter	Pin diameter	Width over inner link	Plate depth	Transverse pitch	Pin length	Connecting pin length	Bearing area	Average tensile strength	Weight	Straight sided plate	Loose parts		
	p														A	B	E
	Inch	mm	b ₁ min.	d ₁ max.	d ₂ max.	b ₂ max.	ε	e	a ₁ max.	a ₃ max.	A	F _B	q	A	B	E	
08 B - 1 SS CB	0.50	12.7	7.75	8.51	4.45	11.30	11.6	-	16.7	19.0	0.50	11 000	0.7		x	x	x
10 B - 1 SS CB	0.625	15.875	9.65	10.16	5.08	13.28	13.8	-	18.9	22.0	0.67	13 000	0.9	x	x	x	x
12 B - 1 SS CB	0.75	19.05	11.68	12.07	5.72	15.62	15.9	-	22.3	25.1	0.89	17 500	1.15	x	x	x	x
16 B - 1 SS CB	1.00	25.4	17.02	15.88	8.28	25.40	20.8	-	35.4	40.8	2.10	44 000	2.6	x	x	x	x

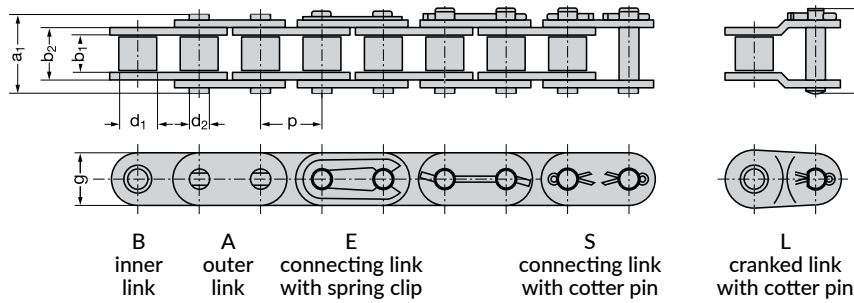

Chain No.	Pitch		Width between inner plates	Roller diameter	Pin diameter	Width over inner link	Plate depth	Transverse pitch	Pin length	Connecting pin length	Bearing area	Average tensile strength	Weight	Straight sided plate	Loose parts		
	p														A	B	E
	Inch	mm	b ₁ min.	d ₁ max.	d ₂ max.	b ₂ max.	ε	e	a ₁ max.	a ₃ max.	A	F _B	q	A	B	E	
08 B - 2 SS CB	0.50	12.7	7.75	8.51	4.45	11.30	11.6	13.92	31.0	33.0	1.01	20 400	1.4		x	x	x
10 B - 2 SS CB	0.625	15.875	9.65	10.16	5.08	13.28	13.8	16.59	35.5	38.6	1.35	26 000	1.8	x	x	x	x
12 B - 2 SS CB	0.75	19.05	11.68	12.07	5.72	15.62	15.9	19.46	41.7	44.4	1.79	35 000	2.3	x	x	x	x
16 B - 2 SS CB	1.00	25.4	17.02	15.88	8.28	25.40	20.8	31.88	67.4	72.8	4.21	81 000	5.3	x	x	x	x

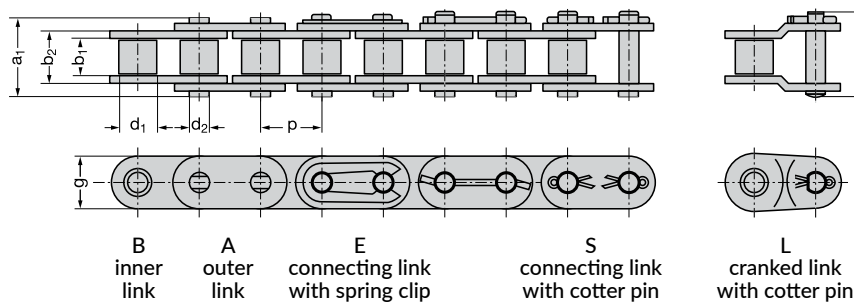

Connecting Dimensions for Rexnord® Roller Chains — European and American standards

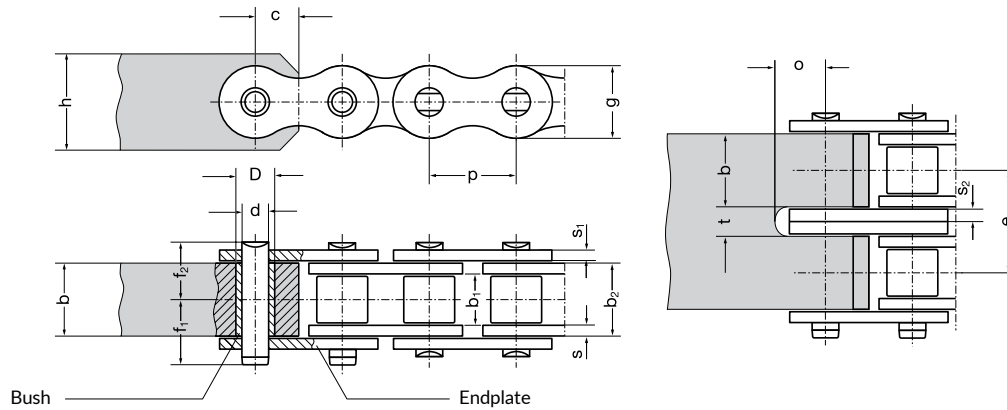

- Required material tensile strength of fixing elements: at least 490 N/mm²
- To increase wear resistance, fit a bush (surface hardness rating approximately 60 HRC) to the connecting element, if joint mobility is required at the connection point.
Hardened bushes are not required in case of static loading.
Please order bushes using the corresponding chain part number
- The bush bore diameters d^{C10} result from press-fitting in bore diameter D^{S7} .
If no bushes are fitted, the bore d^{C10} is inserted directly into the connection element

Connecting dimensions for Rexnord Roller Chains, European standard, ISO 606 (DIN 8187)

Chain no.	Pitch		Width between inner plates		Width over inner link		Plate thickness		Plate depth		Transverse pitch		Bore diameter							
	p		b_1 min.		b_2 max.		s		g		e		d^{C10}		D^{S7}		t		o	
	inch	mm	mm	mm	mm	mm	mm	mm	mm	mm	mm	mm	mm	mm	mm	mm	mm	mm	mm	mm
08 B	0.50	12.70	7.75	11.30	1.70	1.70	1.25	11.60	13.92	10.30	8.40	11	11.20	6.0	4.45	6.27	2.7	7.5		
10 B	0.625	15.875	9.65	13.28	1.70	1.50	1.50	14.60	16.59	11.30	9.40	13	13.20	7.5	5.08	7.00	3.2	8.0		
12 B	0.75	19.05	11.68	15.62	1.80	1.80	1.80	15.90	19.46	13.20	11.10	16	15.60	10.0	5.72	8.75	3.8	9.5		
16 B	1.00	25.40	17.02	25.40	3.75	3.05	3.05	20.50	31.88	21.60	17.70	20	25.40	14.0	8.28	11.70	6.4	13.0		
20 B	1.25	31.75	19.56	29.00	4.50	3.50	3.50	25.70	36.45	24.10	20.20	26	29.00	16.5	10.19	14.00	7.4	16.5		
24 B	1.50	38.10	25.40	37.90	6.00	5.00	5.00	33.00	48.36	31.60	26.90	33	37.90	19.5	14.63	18.99	10.6	20.0		
28 B	1.75	44.45	30.99	46.50	6.50	5.50	6.00	37.00	59.56	36.60	31.60	36	46.50	23.0	15.90	21.64	12.6	24.0		
32 B	2.00	50.80	30.99	45.50	7.00	6.30	6.30	41.20	58.55	38.40	32.50	42	45.50	27.0	17.81	23.12	13.2	27.0		
40 B	2.50	63.50	38.10	55.70	8.50	8.00	8.00	51.50	72.29	47.50	39.40	52	55.70	35.0	22.89	29.18	16.6	35.0		
48 B	3.00	76.20	45.72	70.50	12.00	10.00	10.00	65.00	91.21	56.00	49.20	64	70.50	40.0	29.24	37.90	20.6	40.0		
56 B	3.50	88.90	53.34	81.30	13.60	12.00	12.00	80.00	106.60	64.80	57.80	77	81.30	45.0	34.32	43.50	25.0	51.0		

Connecting dimensions for Rexnord Roller Chains, American standard, ISO 606 (DIN 8188)

Chain no.	Pitch		Width between inner plates		Width over inner link		Plate thickness		Plate depth		Transverse pitch		Bore diameter							
	p		b_1 min.		b_2 max.		s		g		e		d^{C10}		D^{S7}		t		o	
	inch	mm	mm	mm	mm	mm	mm	mm	mm	mm	mm	mm	mm	mm	mm	mm	mm	mm	mm	mm
40	0.50	12.70	7.85	11.15	1.50	1.50	1.50	11.60	14.38	11.2	8.1	11	11.10	6.0	3.96	5.98	3.2	7.0		
50	0.625	15.875	9.40	13.80	2.00	2.00	2.00	14.60	18.11	12.0	10.2	13	13.80	7.7	5.08	7.65	4.2	9.0		
60	0.75	19.05	12.57	17.70	2.40	2.40	2.40	17.80	22.78	14.4	12.8	16	17.60	9.0	5.94	9.00	5.0	10.0		
80	1.00	25.40	15.75	22.50	3.05	3.05	3.05	23.60	29.29	20.4	16.5	22	22.30	12.0	7.92	11.67	6.8	14.0		
100	1.25	31.75	18.90	27.40	4.00	4.00	4.00	29.20	35.76	23.7	19.7	26	27.40	15.5	9.53	13.82	8.4	17.5		
120	1.50	38.10	25.22	35.30	4.70	4.70	4.70	34.40	45.44	30.0	24.9	30	35.20	18.5	11.10	16.13	9.8	20.0		
140	1.75	44.45	25.22	37.00	5.50	5.50	5.50	40.80	48.87	31.6	26.7	36	37.00	21.5	12.70	18.29	11.6	23.5		
160	2.00	50.80	31.55	45.00	6.30	6.30	6.30	47.80	58.55	36.4	31.8	42	44.70	24.0	14.27	20.70	13.2	27.5		
180	2.25	57.15	35.48	50.50	7.00	7.00	7.00	54.00	65.35	41.4	35.7	47	50.60	27.0	17.46	25.35	14.6	32.0		
200	2.50	63.50	37.85	54.70	8.00	8.00	8.00	59.50	71.55	45.0	39.0	52	54.60	30.0	19.84	28.38	16.6	34.5		
240	3.00	76.20	47.35	67.50	9.50	9.50	9.50	70.00	87.33	55.5	47.4	62	67.50	37.0	23.80	34.28	19.6	41.0		

Overview of Regal Rexnord™ Roller Chain Product Portfolio

Extreme Performance Roller Chain

Chain	Static loading	Dynamic loading	Power rating	Wear resistance	Acid corrosion resistance	Damp corrosion resistance	Eco-friendly	Ex-Works Lubrication*	Attachments
RexPlus® Roller Chain								VSK016 Food-grade lubricant**	
RexAthletic® Roller Chain								VSK006 Long-life lubricant	
RexHiPro® Roller Chain								VSK001 RexPro lubricant	
RexCarbon® Roller Chain								VSK016 Food-grade lubricant**	
RexPlus Carbon® Roller Chain								VSK016 Food-grade lubricant**	
RexProX® Roller Chain								VSK001 RexPro lubricant	
RexHiPro® Athletic Roller Chain								VSK018 Food-grade lubricating wax**	
ReXtreme® Roller Chain								VSK015 High- temperature lubricant	

* Special or other lubrication types on request

** NSF H1 Certification

High Performance Roller Chain

Chain	Static loading	Dynamic loading	Power rating	Wear resistance	Acid corrosion resistance	Damp corrosion resistance	Eco-friendly	Ex-Works Lubrication*	Attachments
RexPro® Roller Chain								VSK001 RexPro lubricant	

* Special or other lubrication types on request

Approved Performance Roller Chain

Chain	Static loading	Dynamic loading	Power rating	Wear resistance	Acid corrosion resistance	Damp corrosion resistance	Eco-friendly	Ex-Works Lubrication	Attachments
Link-Belt® Roller Chain								Corrosion protection REACH conform	

- Loading capacity
- Damp corrosion resistance
- Acid corrosion resistance
- Wear resistance
- Eco-friendly

PRODUCT CATALOG



Motion Control Solutions Regal Rexnord

Contact us: [rexnord.com/contact](https://www.rexnord.com/contact)

[regalrexnord.com](https://www.regalrexnord.com)

The proper selection and application of products and components, including assuring that the product is safe for its intended use, are the responsibility of the customer. To view our Application Considerations, please visit <https://www.regalrexnord.com/Application-Considerations>. To view our Standard Terms and Conditions of Sale, please visit <https://www.regalrexnord.com/Terms-and-Conditions-of-Sale> (which may redirect to other website locations based on product family).

Regal Rexnord is not indicative of legal entity.

Regal Rexnord, Rexnord, RexAthletic, RexHiPro, RexHiProAthletic, ReXtreme, RexCarbon, RexProX, RexPlus, RexPlusCarbon and LinkBelt are trademarks of Regal Rexnord Corporation or one of its affiliated companies.

© 2017, 2022 Regal Rexnord Corporation, All Rights Reserved. MC22020E • Form# ECE2-002_MA4E

RegalRexnord